

Fig	Grade	Pos	Remarks
1	.		
2	.		
3	.		
4	.		
5	.		
6	.		
7	.		
8	.		
9	.		
10	.		

Positioning
30

Too Low		Trg Violation	
Too High		Wing Rocks	
Interruptions		Disqual Fig	
Insertions		Other(note...)	

"@C" '2pn(f)4...- (1,0) ~~~~~',4.in('"'32.')...2... (2,0) "0D"-o|"44-`h24.'',3bb(8..)-> (-1,0) "@E" ~~~'
5is...''ib8 (2,0) 4% ~~~~~,2iac('"'24')+ ~~~~~ (0,12) "@A" ,9m32,6f- (0,0) ~,24irc,22- (-6,10) "@B" -2j
o15

Fig 1 C	K	Fig 2	K	Fig 3 D	K	Fig 4	K	Fig 5	K	Fig 6 E	K	Fig 7	K	Fig 8 A	K	Fig 9	K	Fig 10 B	K
1.3.14.1	22	1.3.12.4	21	7.4.1.2	15	5.2.1.4	22	8.8.1.1	18	8.4.2.4	14	7.5.5.3	15	7.2.1.1	6	8.5.2.4	11	2.2.3.4	26
9.1.1.2	8	9.1.5.1	2	9.4.3.4	11	9.4.5.2	5	9.1.1.3	10	9.12.1.5	6	9.1.3.2	4	9.1.3.8	12	9.4.4.2	5		
9.9.4.4	11	9.2.2.6	14					9.8.5.1	3	9.8.1.1	7	9.4.2.2	7	9.2.3.6	12	9.2.3.4	9		
9.1.1.1	6	9.1.5.2	4											9.9.3.6	14				
	47		41		26		27		31		27		26		44		25		26



CIVA Advanced
Free Known

Figure K
320
Total K
350

Judges Name	
Signature	Number

Flight #

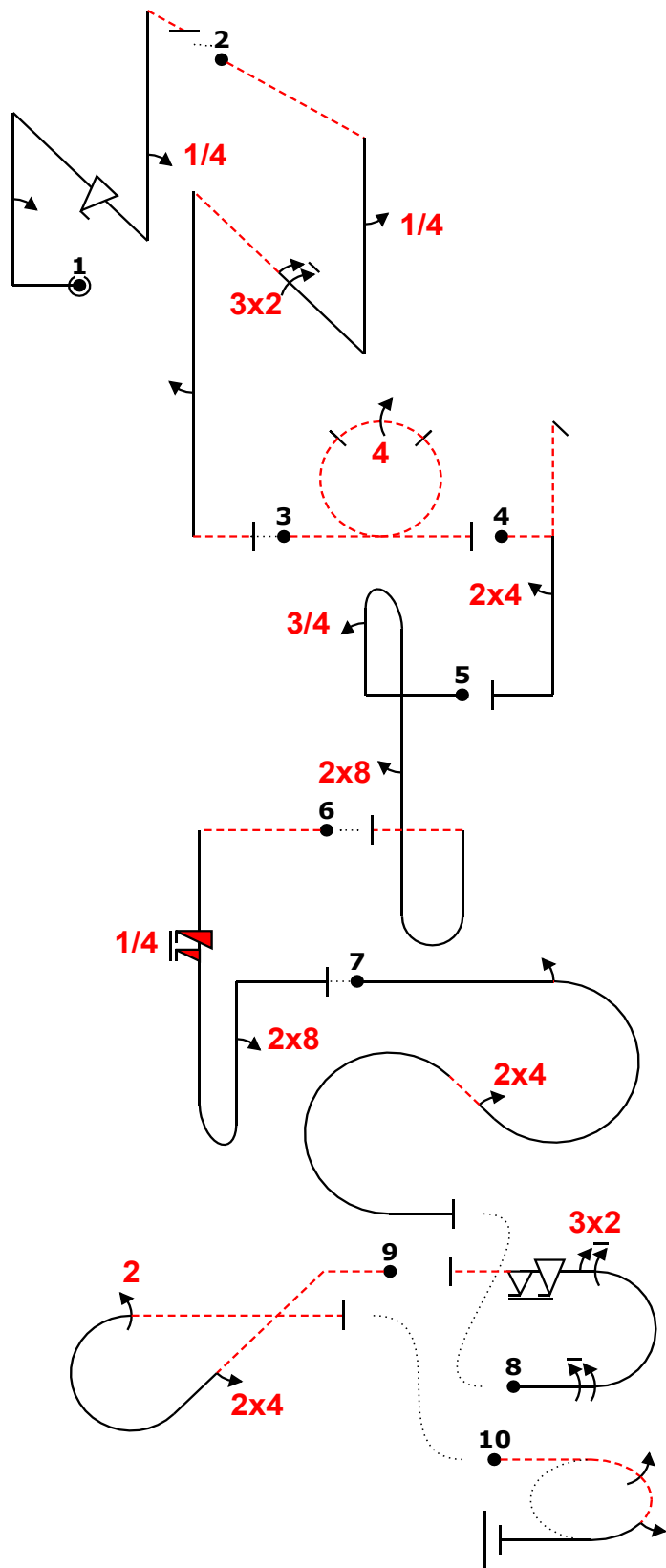
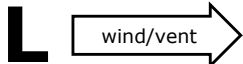

Fig	Grade	Pos	Remarks
1	.		
2	.		
3	.		
4	.		
5	.		
6	.		
7	.		
8	.		
9	.		
10	.		

Positioning	30	.
-------------	----	---

Too Low		Trg Violation	
Too High		Wing Rocks	
Interruptions		Disqual Fig	
Insertions		Other(note...)	

"@C" '2pn(f)4...- (1,0) ~~~~~',4.in('"'32.'')...2... (2,0) "@D" -o|"44-`h24.'',3bb(8..)-> (-1,0) "@E" ~~~' 5is...''ib8 (2,0) 4% ~~~~~,2iac('"'24')+ ~~~~~ (0,12) "@A" ,9m32,6f- (0,0) -,24irc,22- (-6,10) "@B" -2j o15

Fig 1 C	K	Fig 2	K	Fig 3 D	K	Fig 4	K	Fig 5	K	Fig 6 E	K	Fig 7	K	Fig 8 A	K	Fig 9	K	Fig 10 B	K
1.3.14.1	22	1.3.12.4	21	7.4.1.2	15	5.2.1.4	22	8.8.1.1	18	8.4.2.4	14	7.5.5.3	15	7.2.1.1	6	8.5.2.4	11	2.2.3.4	26
9.1.1.2	8	9.1.5.1	2	9.4.3.4	11	9.4.5.2	5	9.1.1.3	10	9.12.1.5	6	9.1.3.2	4	9.1.3.8	12	9.4.4.2	5		
9.9.4.4	11	9.2.2.6	14					9.8.5.1	3	9.8.1.1	7	9.4.2.2	7	9.2.3.6	12	9.2.3.4	9		
9.1.1.1	6	9.1.5.2	4											9.9.3.6	14				
	47		41		26		27		31		27		26		44		25		26

Pilot: Miroslav Cerny

A/C: XP-30 D-ESXA

Team: CZE



Figure K
312
Total K
342

Judges Name		Flight #
Signature	Number	

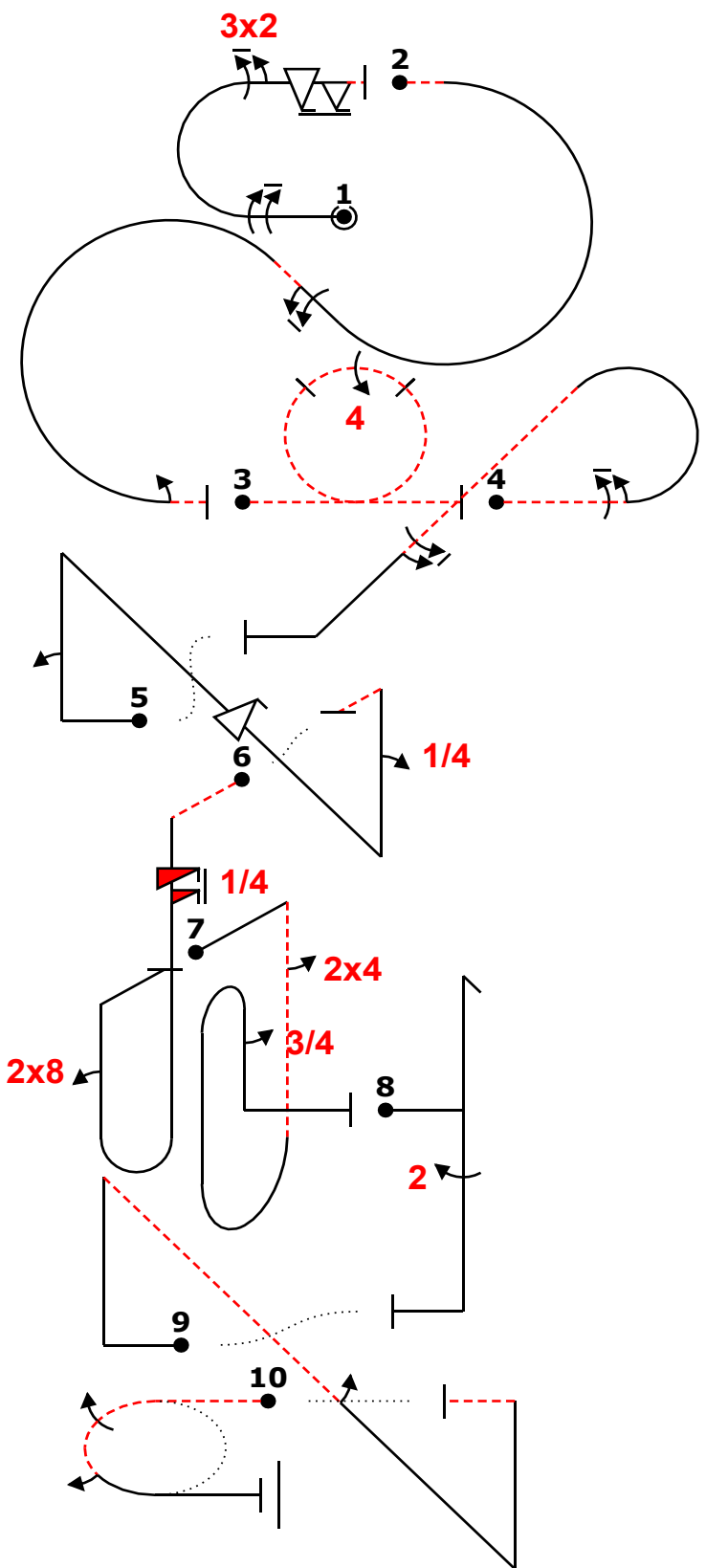

Fig	Grade	Pos	Remarks
1	.		
2	.		
3	.		
4	.		
5	.		
6	.		
7	.		
8	.		
9	.		
10	.		

Positioning
30

Too Low		Trg Violation	
Too High		Wing Rocks	
Interruptions		Disqual Fig	
Insertions		Other(note...)	

ed "@A" ,9m32,6f- 11% - 11% iac(6)2- "0" -o44- 6c...6 (-2,5) "@C" 2pn(.f..),4- (-2,2) "@E" - 5is...ib 8 ~ 24...ibb()3 h,22.. (-8,2) n(...'2...)- (-6,0) "@B" -2 jo15

Fig 1 A	K	Fig 2	K	Fig 3 D	K	Fig 4	K	Fig 5 C	K	Fig 6 E	K	Fig 7	K	Fig 8	K	Fig 9	K	Fig 10 B	K
7.2.1.1	6	7.5.7.4	15	7.4.1.2	15	8.5.8.2	11	1.3.14.1	22	8.4.2.4	14	8.8.8.3	19	5.2.1.1	17	1.3.11.1	20	2.2.3.4	26
9.1.3.8	12	9.1.2.6	12	9.4.3.4	11	9.1.3.6	10	9.1.1.2	8	9.12.1.5	6	9.4.5.2	5	9.2.5.4	9	9.1.4.2	4		
9.2.3.6	12	9.1.3.2	4			9.1.4.6	10	9.9.4.4	11	9.8.1.1	7	9.1.5.3	6						
9.9.3.6	14					9.1.1.1	6												
	44		31		26		31		47		27		30		26		24		26

Pilot: Cihak

A/C: 330LX SP-KDM

Team: CZE

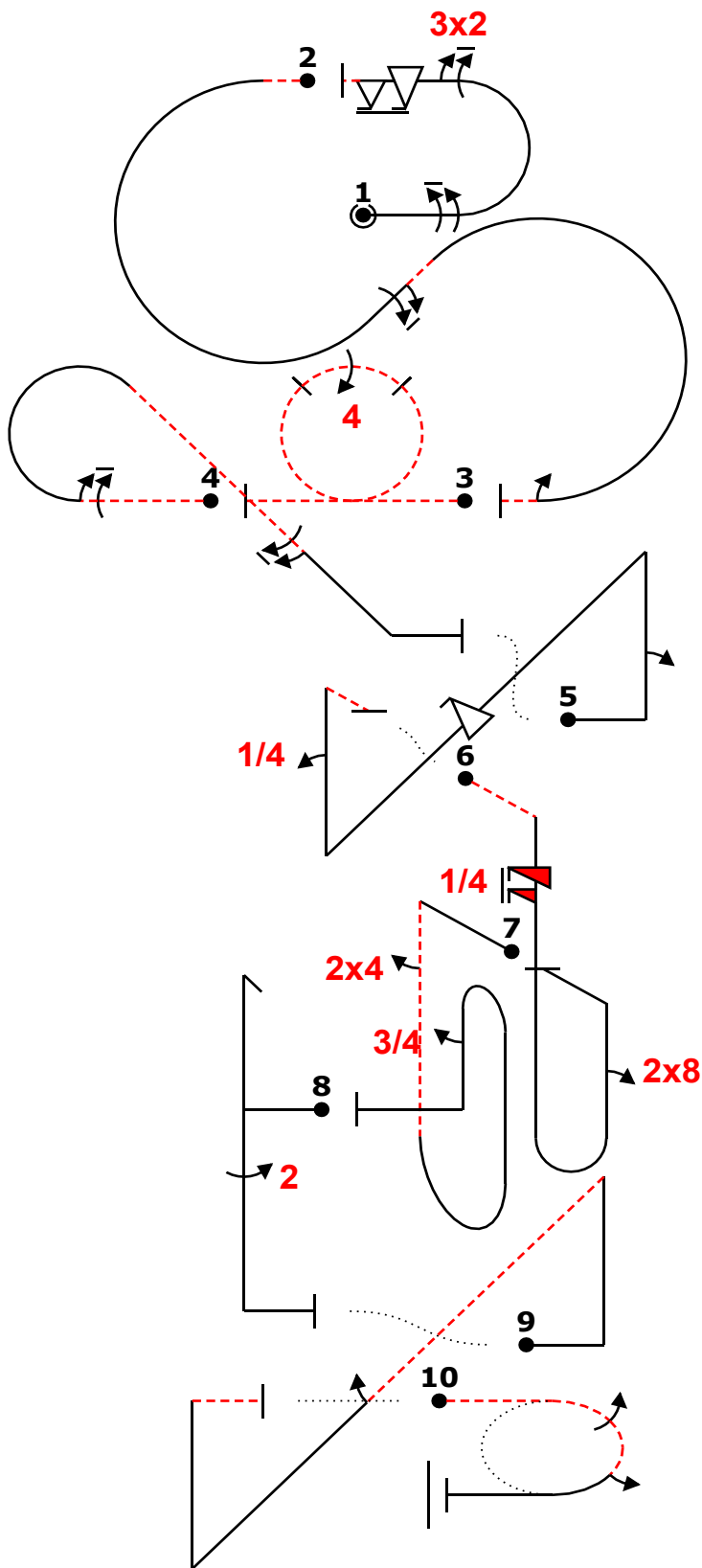
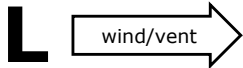

Fig	Grade	Pos	Remarks
1	.		
2	.		
3	.		
4	.		
5	.		
6	.		
7	.		
8	.		
9	.		
10	.		

Positioning **30** .

Too Low		Trg Violation	
Too High		Wing Rocks	
Interruptions		Disqual Fig	
Insertions		Other(note...)	

ed "@A" ,9m32,6f- 11% - 11% iac(6)2- "@0" -o44- 6c... '6" (-2,5) "
@C" 2pn(.f. .) ,4- (-2,2) "@E" - 5is. ib' 8 ~ 24. ibb() 3 h, 22. (-8,2) n(. '2.)- (-6,0) "@B" -2
jo15

Fig 1 A	K	Fig 2	K	Fig 3 D	K	Fig 4	K	Fig 5 C	K	Fig 6 E	K	Fig 7	K	Fig 8	K	Fig 9	K	Fig 10 B	K
7.2.1.1	6	7.5.7.4	15	7.4.1.2	15	8.5.8.2	11	1.3.14.1	22	8.4.2.4	14	8.8.8.3	19	5.2.1.1	17	1.3.11.1	20	2.2.3.4	26
9.1.3.8	12	9.1.2.6	12	9.4.3.4	11	9.1.3.6	10	9.1.1.2	8	9.12.1.5	6	9.4.5.2	5	9.2.5.4	9	9.1.4.2	4		
9.2.3.6	12	9.1.3.2	4			9.1.4.6	10	9.9.4.4	11	9.8.1.1	7	9.1.5.3	6						
9.9.3.6	14					9.1.1.1	6												
	44		31		26		31		47		27		30		26		24		26

wind/vent **R**

Figure K
320
Total K
350

Judges Name
Signature
Number

Flight #

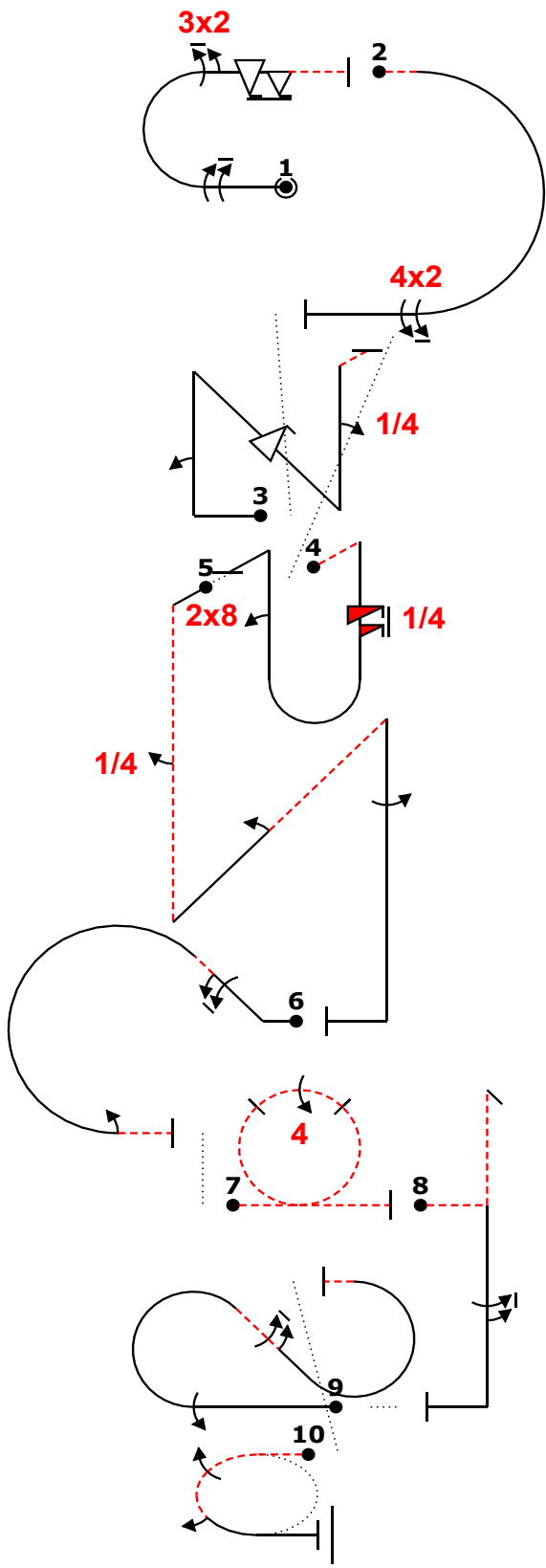

Fig	Grade	Pos	Remarks
1	.		
2	.		
3	.		
4	.		
5	.		
6	.		
7	.		
8	.		
9	.		
10	.		

Positioning
30

Too Low		Trg Violation	
Too High		Wing Rocks	
Interruptions		Disqual Fig	
Insertions		Other(note...)	

ed "@A" ,9m32,6f- 11% -... a["42+ [1,14] "@C" 2pn('f'),4-^ [-7,17] "@E" 5%5isib"8'+... (2,-1) '+... ,4...in('2...')1... 8% 6...rc2-..... [0,5] "@D" -o44- -h.6.' (-2,0) 1ac(6)-..... [3,12] "@B"-2jo15+...

Fig 1 A	K	Fig 2	K	Fig 3 C	K	Fig 4 E	K	Fig 5	K	Fig 6	K	Fig 7 D	K	Fig 8	K	Fig 9	K	Fig 10 B	K
7.2.1.1	6	7.2.1.4	6	1.3.14.1	22	8.4.2.4	14	1.3.16.3	21	8.5.4.1	11	7.4.1.2	15	5.2.1.4	22	7.5.2.1	15	2.2.3.4	26
9.1.3.8	12	9.2.3.8	15	9.1.1.2	8	9.12.1.5	6	9.1.5.1	2	9.1.2.6	12	9.4.3.4	11	9.1.5.6	10	9.1.3.4	8		
9.2.3.6	12			9.9.4.4	11	9.8.1.1	7	9.1.2.2	6	9.1.3.2	4					9.1.4.6	10		
9.9.3.6	14			9.1.1.1	6	9.1.5.4	8												
	44		21		47		27		37		27		26		32		33		26

Pilot: Jan Jílek

A/C: EXTRA 330SC OK-LPJ Team: CZE



CIVA Advanced

Free Known

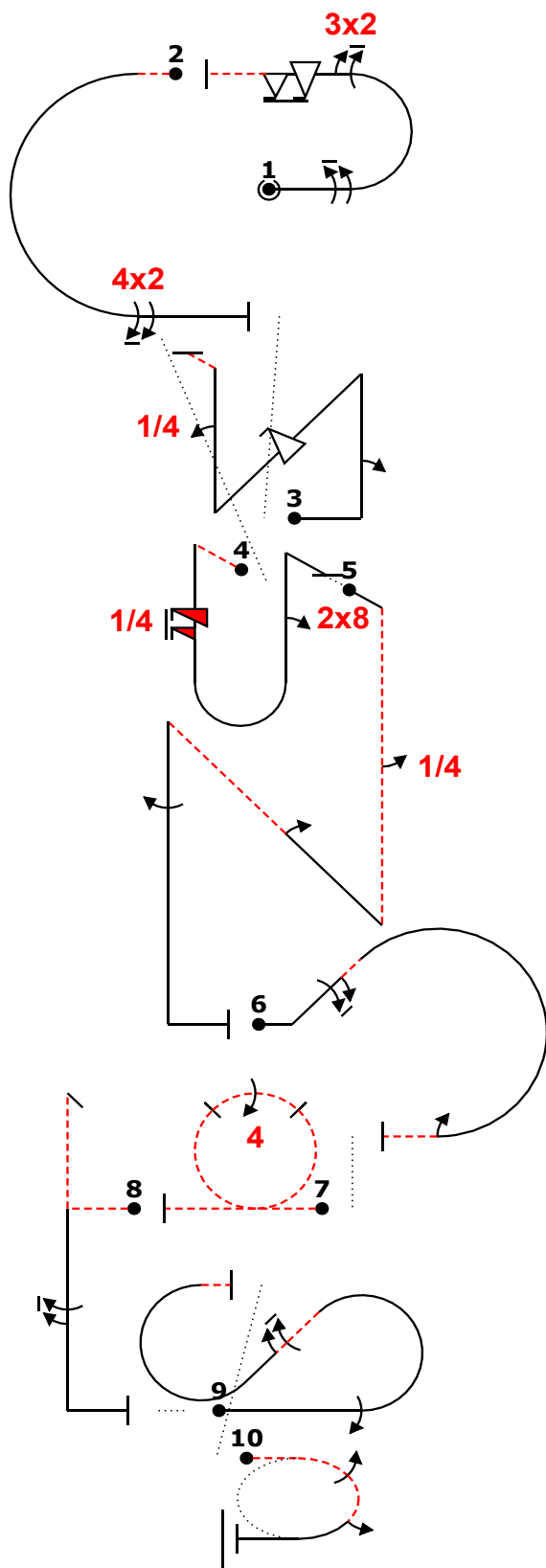
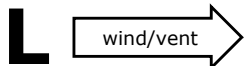

Figure K

320

Total K

350

Judges Name	
Signature	Number

Flight #

Fig	Grade	Pos	Remarks
1	.		
2	.		
3	.		
4	.		
5	.		
6	.		
7	.		
8	.		
9	.		
10	.		

Positioning

30

.

Too Low		Trg Violation	
Too High		Wing Rocks	
Interruptions		Disqual Fig	
Insertions		Other(note...)	

ed "@A" ,9m32,6f- 11% -"a"["42+ [1,14] "@C" 2pn('f'),4-^ [-7,17] "@E" 5% "5isib"8'+* (2,-1) '+... ,4, 'in('2...')1... 8% "6" rc2- " [0,5] "@D" "o44 -h.6.' (-2,0) "1ac(6)- " [3,12] "@B" "2jo15+ "

Fig 1 A	K	Fig 2	K	Fig 3 C	K	Fig 4 E	K	Fig 5	K	Fig 6	K	Fig 7 D	K	Fig 8	K	Fig 9	K	Fig 10 B	K
7.2.1.1	6	7.2.1.4	6	1.3.14.1	22	8.4.2.4	14	1.3.16.3	21	8.5.4.1	11	7.4.1.2	15	5.2.1.4	22	7.5.2.1	15	2.2.3.4	26
9.1.3.8	12	9.2.3.8	15	9.1.1.2	8	9.12.1.5	6	9.1.5.1	2	9.1.2.6	12	9.4.3.4	11	9.1.5.6	10	9.1.3.4	8		
9.2.3.6	12			9.9.4.4	11	9.8.1.1	7	9.1.2.2	6	9.1.3.2	4					9.1.4.6	10		
9.9.3.6	14			9.1.1.1	6			9.1.5.4	8										
	44		21		47		27		37		27		26		32		33		26

Pilot: Jan Jílek

A/C: EXTRA 330SC OK-LPJ Team: CZE

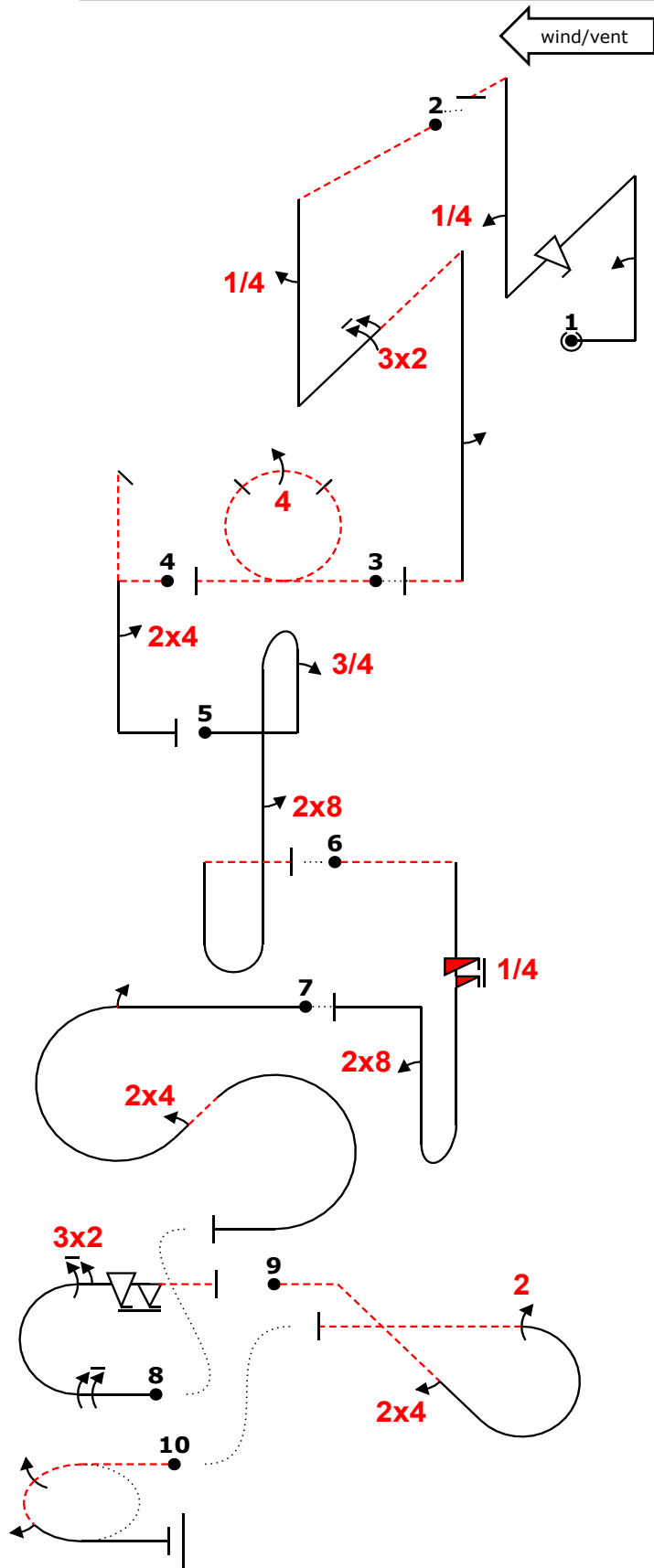

Fig	Grade	Pos	Remarks
1	.		
2	.		
3	.		
4	.		
5	.		
6	.		
7	.		
8	.		
9	.		
10	.		

Positioning	30	.
-------------	----	---

Too Low		Trg Violation	
Too High		Wing Rocks	
Interruptions		Disqual Fig	
Insertions		Other(note...)	

"@C" '2pn(f)4...- (1,0) ~~~~~',4.in('"'32.')...2... (2,0) "@D" -o|"44- `h24.' ,3bb(8..)-> (-1,0) "@E" ~~~' 5is...''ib8 (2,0) 4% ~~~~~,2iac('"'24')+ ~~~~~ (0,12) "@A" ,9m32,6f- (0,0) -,24irc,22- (-6,10) "@B" -2j o15

Fig 1 C	K	Fig 2	K	Fig 3 D	K	Fig 4	K	Fig 5	K	Fig 6 E	K	Fig 7	K	Fig 8 A	K	Fig 9	K	Fig 10 B	K
1.3.14.1	22	1.3.12.4	21	7.4.1.2	15	5.2.1.4	22	8.8.1.1	18	8.4.2.4	14	7.5.5.3	15	7.2.1.1	6	8.5.2.4	11	2.2.3.4	26
9.1.1.2	8	9.1.5.1	2	9.4.3.4	11	9.4.5.2	5	9.1.1.3	10	9.12.1.5	6	9.1.3.2	4	9.1.3.8	12	9.4.4.2	5		
9.9.4.4	11	9.2.2.6	14					9.8.5.1	3	9.8.1.1	7	9.4.2.2	7	9.2.3.6	12	9.2.3.4	9		
9.1.1.1	6	9.1.5.2	4											9.9.3.6	14				
	47		41		26		27		31		27		26		44		25		26

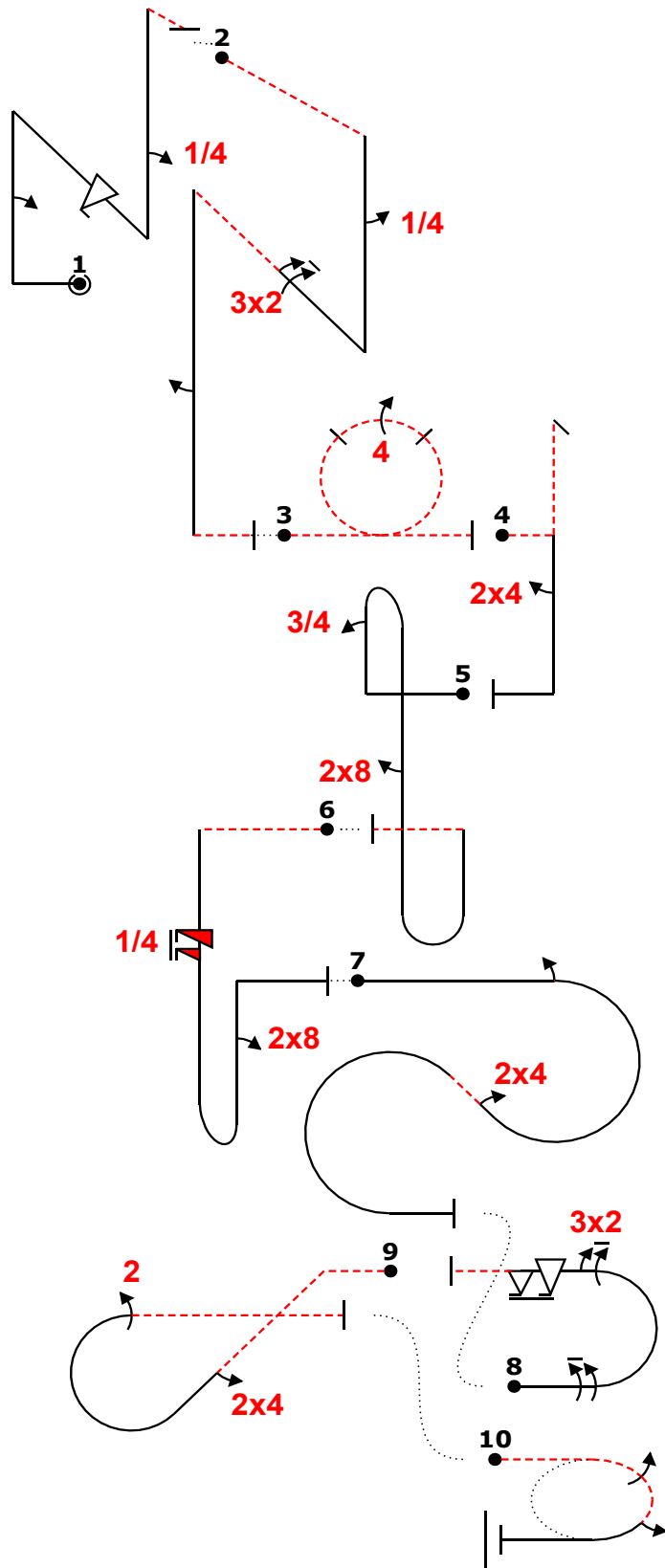
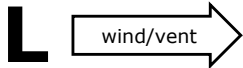

Fig	Grade	Pos	Remarks
1	.		
2	.		
3	.		
4	.		
5	.		
6	.		
7	.		
8	.		
9	.		
10	.		

Positioning
30

Too Low		Trg Violation	
Too High		Wing Rocks	
Interruptions		Disqual Fig	
Insertions		Other(note...)	

"@C" '2pn(f)4...- (1,0) ~~~~~',4.in(''|"32.'')...2...- (2,0) "@D" -o|"44-`h24.'',3bb(8..)-> (-1,0) "@E" ~~~~' 5is...''ib8 (2,0) 4% ~~~~~,2iac(''24')+ ~~~~~ (0,12) "@A" ,9m32,6f- (0,0) -,24irc,22- (-6,10) "@B" -2j o15

Fig 1 C	K	Fig 2	K	Fig 3 D	K	Fig 4	K	Fig 5	K	Fig 6 E	K	Fig 7	K	Fig 8 A	K	Fig 9	K	Fig 10 B	K
1.3.14.1	22	1.3.12.4	21	7.4.1.2	15	5.2.1.4	22	8.8.1.1	18	8.4.2.4	14	7.5.5.3	15	7.2.1.1	6	8.5.2.4	11	2.2.3.4	26
9.1.1.2	8	9.1.5.1	2	9.4.3.4	11	9.4.5.2	5	9.1.1.3	10	9.12.1.5	6	9.1.3.2	4	9.1.3.8	12	9.4.4.2	5		
9.9.4.4	11	9.2.2.6	14					9.8.5.1	3	9.8.1.1	7	9.4.2.2	7	9.2.3.6	12	9.2.3.4	9		
9.1.1.1	6	9.1.5.2	4											9.9.3.6	14				
	47		41		26		27		31		27		26		44		25		26

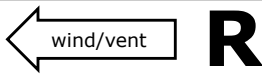

Figure K
320
Total K
350

Judges Name		Flight #
Signature	Number	

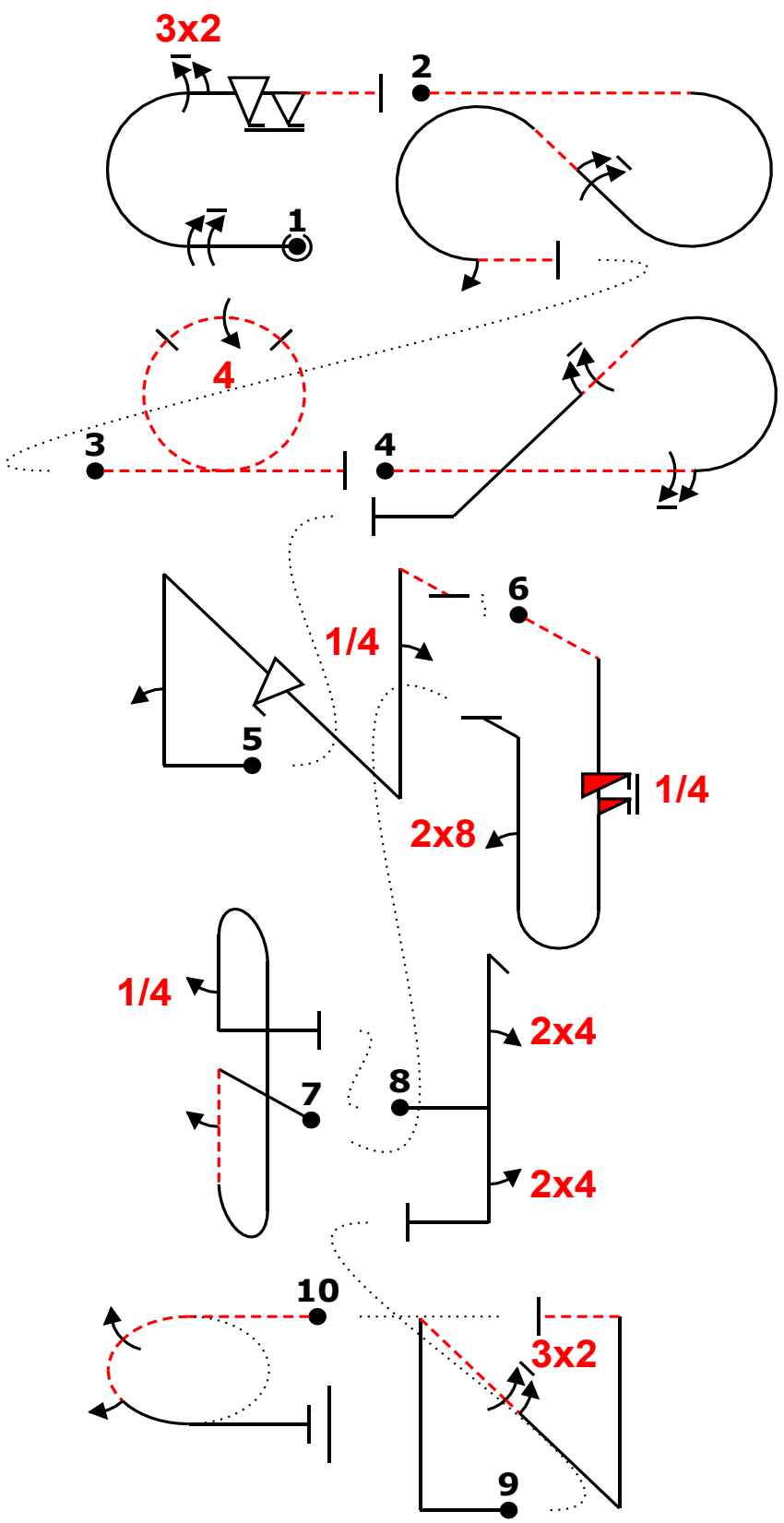

Fig	Grade	Pos	Remarks
1	.		
2	.		
3	.		
4	.		
5	.		
6	.		
7	.		
8	.		
9	.		
10	.		

Positioning
30

Too Low		Trg Violation	
Too High		Wing Rocks	
Interruptions		Disqual Fig	
Insertions		Other(note...)	

ed "@A",9m32,6f-...iac(,6),2...(-27,11) "@0" -o44-,-,6c,6 (-2,13) "@C" /2pn(,f.)',,"|4- (0,-1) "@E" -5is.ib`8'+` (-5,23) ~,,2'ibb(`),4'+' (0,4) ,24h24 (9,15) n(`32.)- (-7,0) "@B" -2jo15

Fig 1 A	K	Fig 2	K	Fig 3 D	K	Fig 4	K	Fig 5 C	K	Fig 6 E	K	Fig 7	K	Fig 8	K	Fig 9	K	Fig 10 B	K
7.2.1.1	6	7.5.7.4	15	7.4.1.2	15	8.5.8.2	11	1.3.14.1	22	8.4.2.4	14	8.8.8.3	19	5.2.1.1	17	1.3.11.1	20	2.2.3.4	26
9.1.3.8	12	9.1.2.6	12	9.4.3.4	11	9.1.3.6	10	9.1.1.2	8	9.12.1.5	6	9.1.5.2	4	9.4.1.2	9	9.2.4.6	12		
9.2.3.6	12	9.1.3.2	4			9.1.4.6	10	9.9.4.4	11	9.8.1.1	7	9.1.5.1	2	9.4.5.2	5				
9.9.3.6	14							9.1.1.1	6										
	44		31		26		31		47		27		25		31		32		26

Pilot: Sami Kontio

A/C: EXTRA 300 SE-XIZ

Team: FIN



Figure K
320
Total K
350

Judges Name		Flight #
Signature	Number	

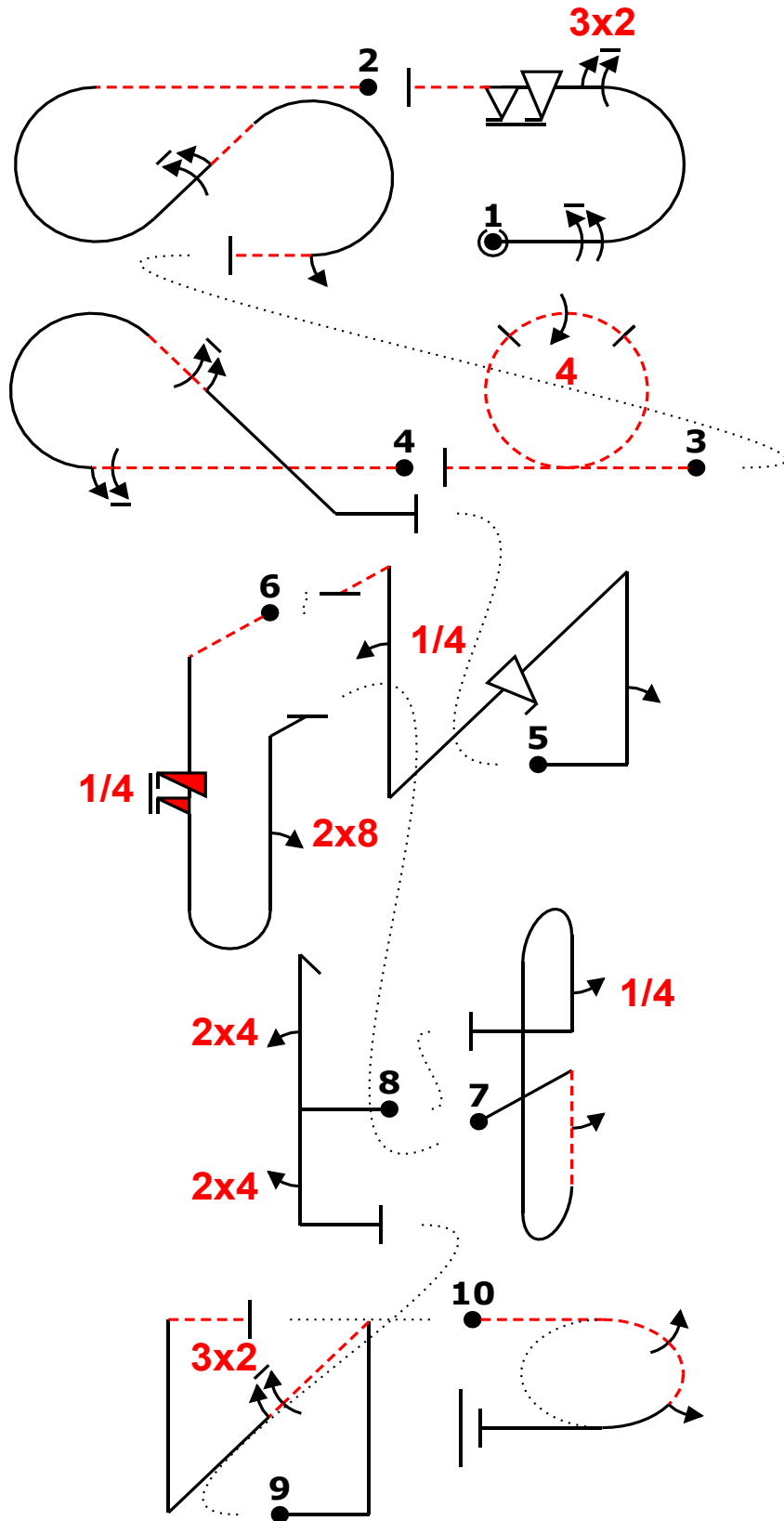
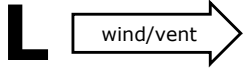

Fig	Grade	Pos	Remarks
1	.		
2	.		
3	.		
4	.		
5	.		
6	.		
7	.		
8	.		
9	.		
10	.		

Positioning
30 .

Too Low		Trg Violation	
Too High		Wing Rocks	
Interruptions		Disqual Fig	
Insertions		Other(note...)	

ed "@A",9m32,6f-...iac(,6),2... (-27,11) "@0" -044--6c,6 (-2,13) "@C" /2pn(,f.)',,"|4- (0,-1) "E" -5is.ib`8'+... (-5,23) ~',2'ibb('),4''+ (0,4) ,24h24 (9,15) n('32.)- (-7,0) "@B" -2jo15

Fig 1 A	K	Fig 2	K	Fig 3 D	K	Fig 4	K	Fig 5 C	K	Fig 6 E	K	Fig 7	K	Fig 8	K	Fig 9	K	Fig 10 B	K
7.2.1.1	6	7.5.7.4	15	7.4.1.2	15	8.5.8.2	11	1.3.14.1	22	8.4.2.4	14	8.8.8.3	19	5.2.1.1	17	1.3.11.1	20	2.2.3.4	26
9.1.3.8	12	9.1.2.6	12	9.4.3.4	11	9.1.3.6	10	9.1.1.2	8	9.1.2.1.5	6	9.1.5.2	4	9.4.1.2	9	9.2.4.6	12		
9.2.3.6	12	9.1.3.2	4			9.1.4.6	10	9.9.4.4	11	9.8.1.1	7	9.1.5.1	2	9.4.5.2	5				
9.9.3.6	14							9.1.1.1	6										
	44		31		26		31		47		27		25		31		32		26

Pilot: Sami Kontio

A/C: EXTRA 300 SE-XIZ

Team: FIN

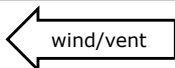

R

Figure K

320

Total K

350

Judges Name	
Signature	Number

Flight #

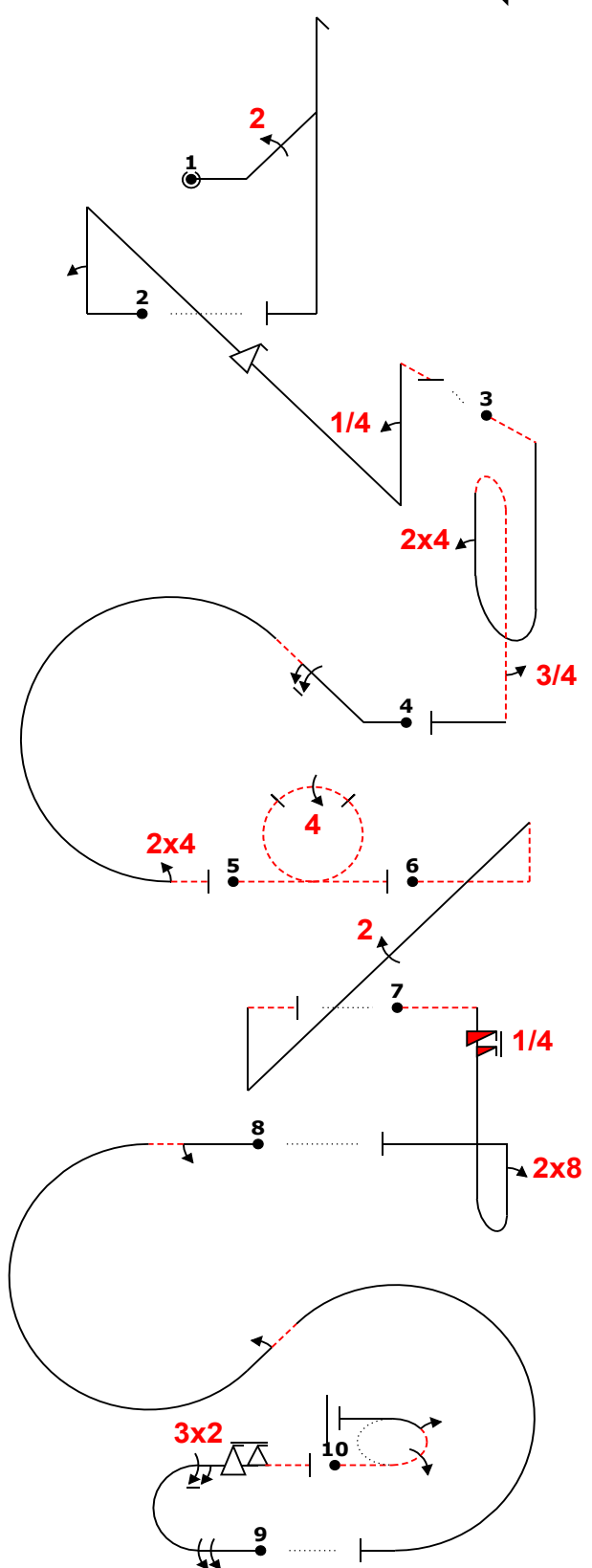

Fig	Grade	Pos	Remarks
1	.		
2	.		
3	.		
4	.		
5	.		
6	.		
7	.		
8	.		
9	.		
10	.		

Positioning	30	.
-------------	----	---

Too Low		Trg Violation	
Too High		Wing Rocks	
Interruptions		Disqual Fig	
Insertions		Other(note...)	

/22dh... (-6,0) "@C" 2'pn(...'f...)'4'- (1,1) -...'ibpb(.....24).....3 20%6"rc24-
 "@D" -o44-pn(...',22.....)' (4,0) "@E" -'5is... 'ib',8'+ (-6,0) 18%2'iac'
 '2'....)+ (-4,0) "@A" -1% 9m,|"32,6f- -3% "@B" -2jo15>

Fig 1	K	Fig 2 C	K	Fig 3	K	Fig 4	K	Fig 5 D	K	Fig 6	K	Fig 7 E	K	Fig 8	K	Fig 9 A	K	Fig 10 B	K
5.3.1.1	18	1.3.14.1	22	8.8.3.4	20	8.5.4.1	11	7.4.1.2	15	1.3.9.2	24	8.4.2.4	14	7.5.5.3	15	7.2.1.1	6	2.2.3.4	26
9.2.2.4	11	9.1.1.2	8	9.4.1.2	9	9.1.2.6	12	9.4.3.4	11	9.2.4.4	9	9.12.1.5	6	9.1.3.2	4	9.1.3.8	12		
		9.9.4.4	11	9.1.5.3	6	9.4.3.2	5					9.8.1.1	7	9.1.2.2	6	9.2.3.6	12		
		9.1.1.1	6													9.9.3.6	14		
	29		47		35		28		26		33		27		25		44		26



CIVA Advanced

Free Known

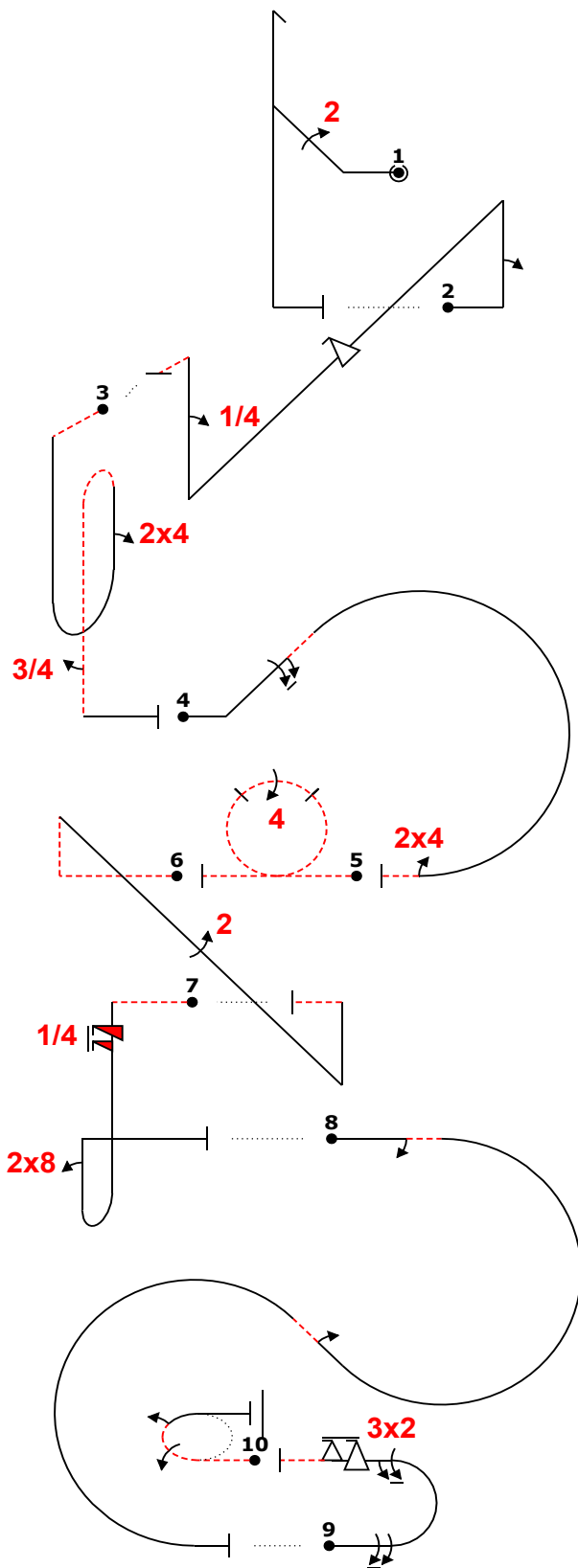
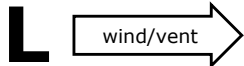

/22dh... (-6,0) "@C" 2'pn(...'f....)'4'- (1,1) -...'ibpb(.....24).....3 20% +.....6''rc24-
 "@D" -o44-pn(.....,22.....) (4,0) "@E"5is...ib',8''+- (-6,0) 18%2'iac'
2'.....+..... (-4,0) "@A" -1% 9m,|"32,6f- -3% "@B" -2jo15>

Figure K

320

Total K

350

Judges Name

Flight #

Signature

Number

Fig	Grade	Pos	Remarks
1	.		
2	.		
3	.		
4	.		
5	.		
6	.		
7	.		
8	.		
9	.		
10	.		

Positioning

30

.

Too Low

Trg Violation

Too High

Wing Rocks

Interruptions

Disqual Fig

Insertions

Other(note...)

Fig 1	K	Fig 2 C	K	Fig 3	K	Fig 4	K	Fig 5 D	K	Fig 6	K	Fig 7 E	K	Fig 8	K	Fig 9 A	K	Fig 10 B	K
5.3.1.1	18	1.3.14.1	22	8.8.3.4	20	8.5.4.1	11	7.4.1.2	15	1.3.9.2	24	8.4.2.4	14	7.5.5.3	15	7.2.1.1	6	2.2.3.4	26
9.2.2.4	11	9.1.1.2	8	9.4.1.2	9	9.1.2.6	12	9.4.3.4	11	9.2.4.4	9	9.12.1.5	6	9.1.3.2	4	9.1.3.8	12		
		9.9.4.4	11	9.1.5.3	6	9.4.3.2	5					9.8.1.1	7	9.1.2.2	6	9.2.3.6	12		
		9.1.1.1	6													9.9.3.6	14		
	29		47		35		28		26		33		27		25		44		26

Pilot: Mario ALBERTI

A/C: Cap 232 FHKAP

Team: FRA



CIVA Advanced
Free Known

wind/vent ← **R**

Figure K
320
Total K
350

Judges Name
Signature
Number

Flight #

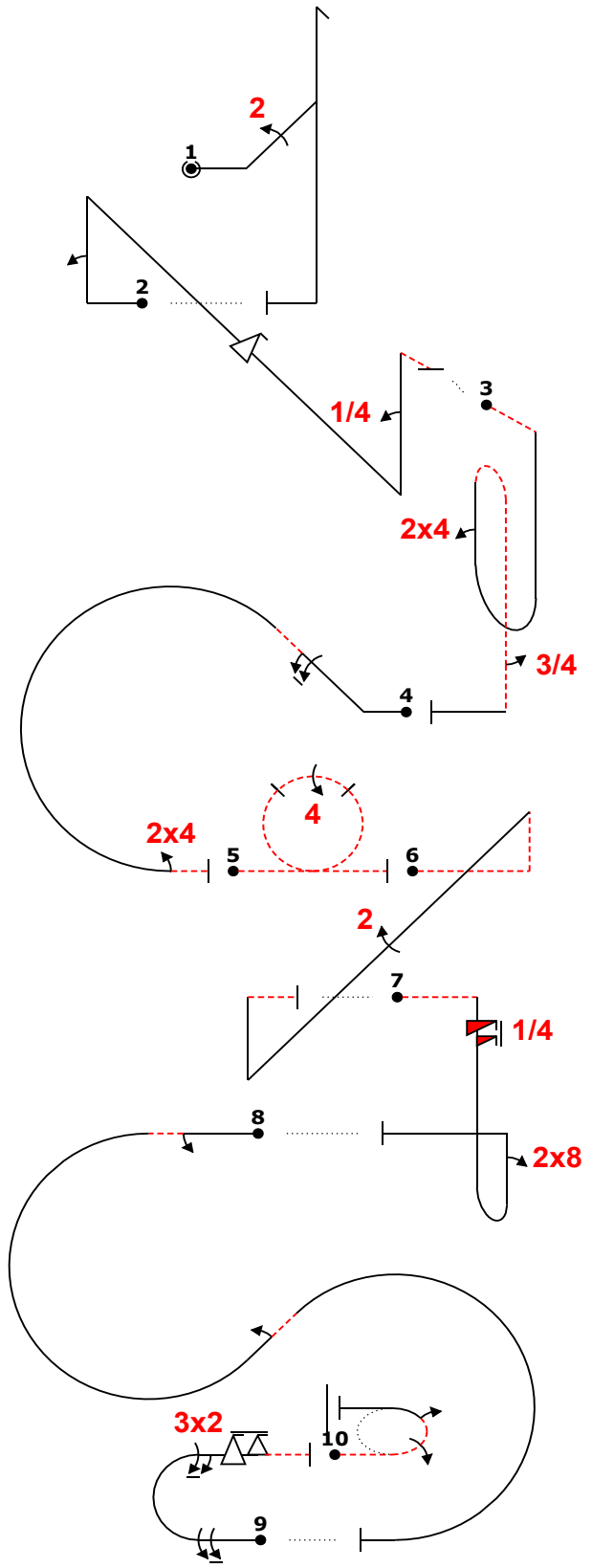

Fig	Grade	Pos	Remarks
1	.		
2	.		
3	.		
4	.		
5	.		
6	.		
7	.		
8	.		
9	.		
10	.		

Positioning
30

Too Low		Trg Violation	
Too High		Wing Rocks	
Interruptions		Disqual Fig	
Insertions		Other(note...)	

/22dh... (-6,0) "@C" 2'pn(...'f...)'4'- (1,1) -...'ibpb(.....24).....3 20%6"rc24-
....."@D" -o44-pn(...',22.....)' (4,0) "@E" -...5is... 'ib',8'+ (-6,0) 18%2'iac'
'2'....)+ (-4,0) "@A" -1% 9m,|"32,6f- -3% "@B" -2jo15>

Fig 1	K	Fig 2 C	K	Fig 3	K	Fig 4	K	Fig 5 D	K	Fig 6	K	Fig 7 E	K	Fig 8	K	Fig 9 A	K	Fig 10 B	K
5.3.1.1	18	1.3.14.1	22	8.8.3.4	20	8.5.4.1	11	7.4.1.2	15	1.3.9.2	24	8.4.2.4	14	7.5.5.3	15	7.2.1.1	6	2.2.3.4	26
9.2.2.4	11	9.1.1.2	8	9.4.1.2	9	9.1.2.6	12	9.4.3.4	11	9.2.4.4	9	9.12.1.5	6	9.1.3.2	4	9.1.3.8	12		
		9.9.4.4	11	9.1.5.3	6	9.4.3.2	5					9.8.1.1	7	9.1.2.2	6	9.2.3.6	12		
		9.1.1.1	6													9.9.3.6	14		
	29		47		35		28		26		33		27		25		44		26

Pilot: Paul CHESNEAU

A/C: EA 330 SC FHMKF

Team: FRA



CIVA Advanced

Free Known

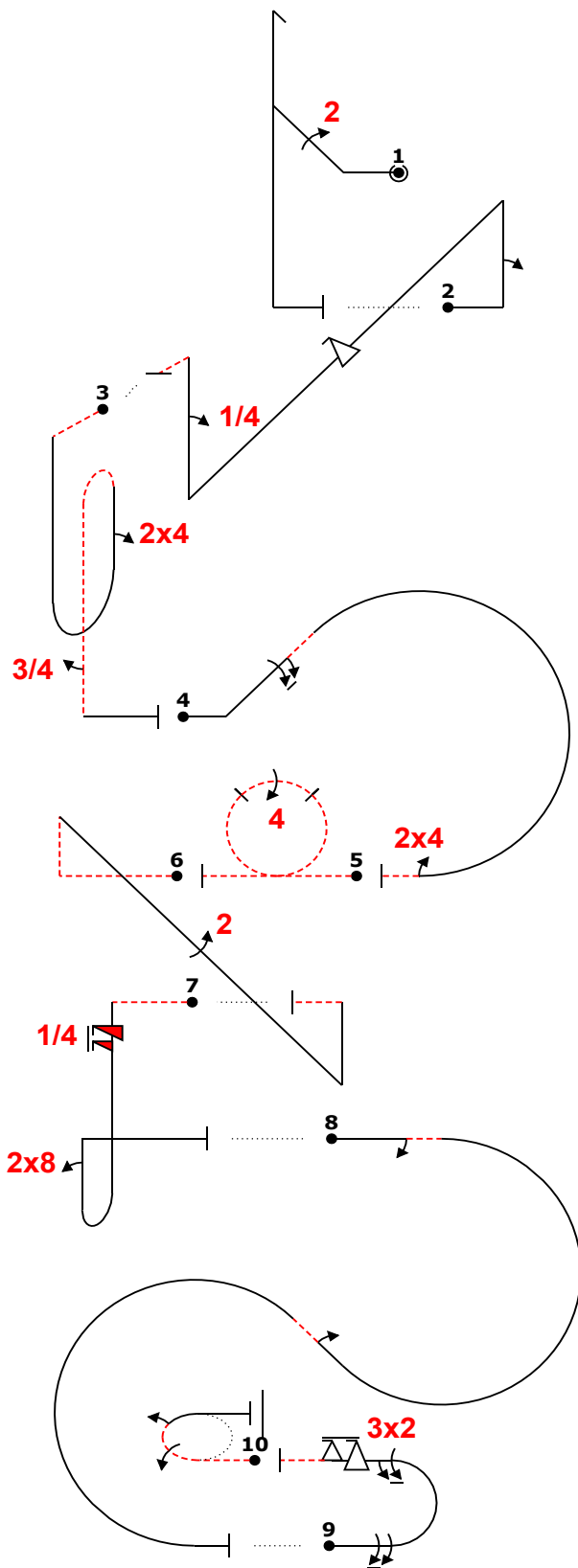
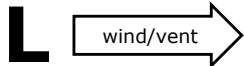

/22dh... (-6,0) "@C" 2'pn(...'f....')'4'- (1,1) -...'ibpb(.....24).....3 20% +.....6''rc24-
 "@D" -o44-pn(.....,22.....) (4,0) "@E" -...5is...ib',8''+- (-6,0) 18%2'iac(
 '2'....)+..... (-4,0) "@A" -1% 9m,|"32,6f- -3% "@B" -2jo15>

Figure K

320

Total K

350

Judges Name

Flight #

Signature

Number

Fig	Grade	Pos	Remarks
1	.		
2	.		
3	.		
4	.		
5	.		
6	.		
7	.		
8	.		
9	.		
10	.		

Positioning

30

.

Too Low

Trg Violation

Too High

Wing Rocks

Interruptions

Disqual Fig

Insertions

Other(note...)

Fig 1	K	Fig 2 C	K	Fig 3	K	Fig 4	K	Fig 5 D	K	Fig 6	K	Fig 7 E	K	Fig 8	K	Fig 9 A	K	Fig 10 B	K
5.3.1.1	18	1.3.14.1	22	8.8.3.4	20	8.5.4.1	11	7.4.1.2	15	1.3.9.2	24	8.4.2.4	14	7.5.5.3	15	7.2.1.1	6	2.2.3.4	26
9.2.2.4	11	9.1.1.2	8	9.4.1.2	9	9.1.2.6	12	9.4.3.4	11	9.2.4.4	9	9.12.1.5	6	9.1.3.2	4	9.1.3.8	12		
		9.9.4.4	11	9.1.5.3	6	9.4.3.2	5					9.8.1.1	7	9.1.2.2	6	9.2.3.6	12		
		9.1.1.1	6													9.9.3.6	14		
	29		47		35		28		26		33		27		25		44		26

Pilot: Paul CHESNEAU

A/C: EA 330 SC FHMKF

Team: FRA



CIVA Advanced

Free Known

wind/vent ←

R

Figure K

320

Total K

350

Judges Name	
Signature	Number

Flight #

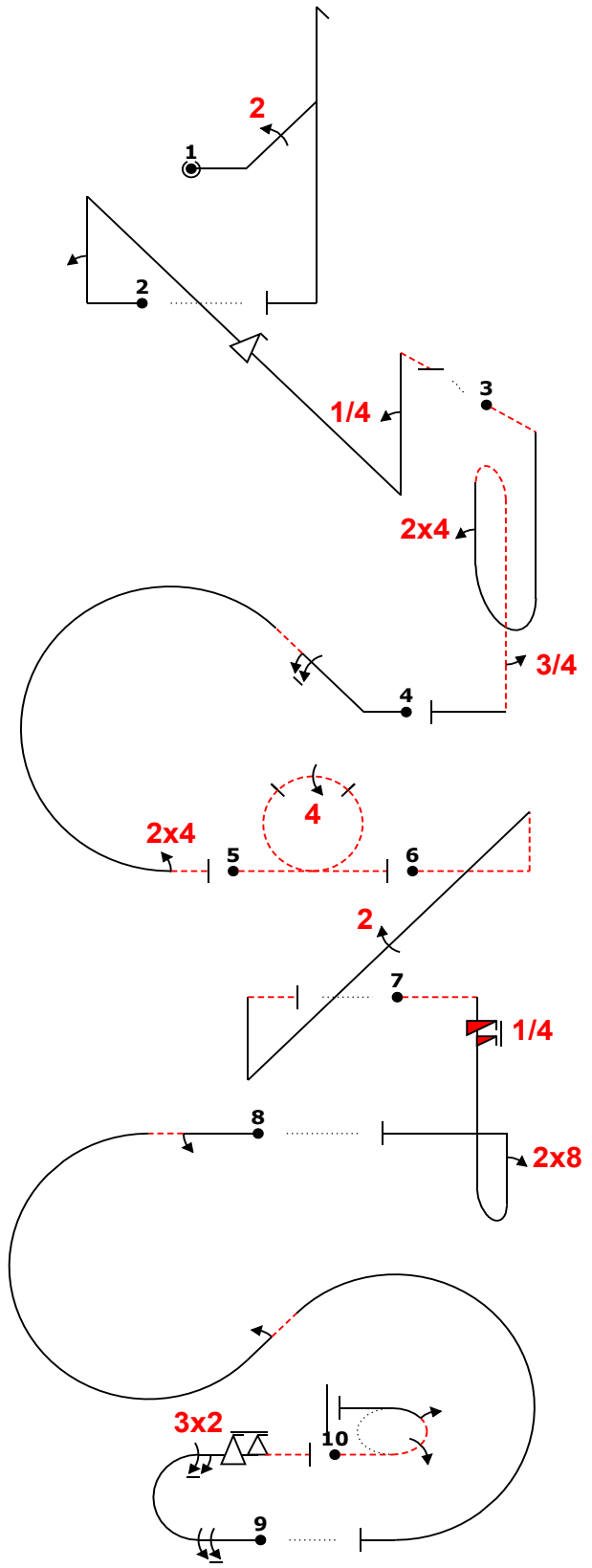

Fig	Grade	Pos	Remarks
1	.		
2	.		
3	.		
4	.		
5	.		
6	.		
7	.		
8	.		
9	.		
10	.		

Positioning 30 .

Too Low		Trg Violation	
Too High		Wing Rocks	
Interruptions		Disqual Fig	
Insertions		Other(note...)	

/22dh... (-6,0) "@C" 2'pn(...'f...)'4'- (1,1) -...'ibpb(.....24).....3 20%6"rc24-
 "@D" -o44-pn(...',22.....)' (4,0) "@E" -'5is... 'ib',8'+ (-6,0) 18%2'iac'
 '2'....)+ (-4,0) "@A" -1% 9m,|"32,6f- -3% "@B" -2jo15>

Fig 1	K	Fig 2 C	K	Fig 3	K	Fig 4	K	Fig 5 D	K	Fig 6	K	Fig 7 E	K	Fig 8	K	Fig 9 A	K	Fig 10 B	K
5.3.1.1	18	1.3.14.1	22	8.8.3.4	20	8.5.4.1	11	7.4.1.2	15	1.3.9.2	24	8.4.2.4	14	7.5.5.3	15	7.2.1.1	6	2.2.3.4	26
9.2.2.4	11	9.1.1.2	8	9.4.1.2	9	9.1.2.6	12	9.4.3.4	11	9.2.4.4	9	9.12.1.5	6	9.1.3.2	4	9.1.3.8	12		
		9.9.4.4	11	9.1.5.3	6	9.4.3.2	5					9.8.1.1	7	9.1.2.2	6	9.2.3.6	12		
		9.1.1.1	6													9.9.3.6	14		
	29		47		35		28		26		33		27		25		44		26

Pilot: Maxime ORTH

A/C: EA 330 SC FHLYK

Team: FRA



CIVA Advanced

Free Known

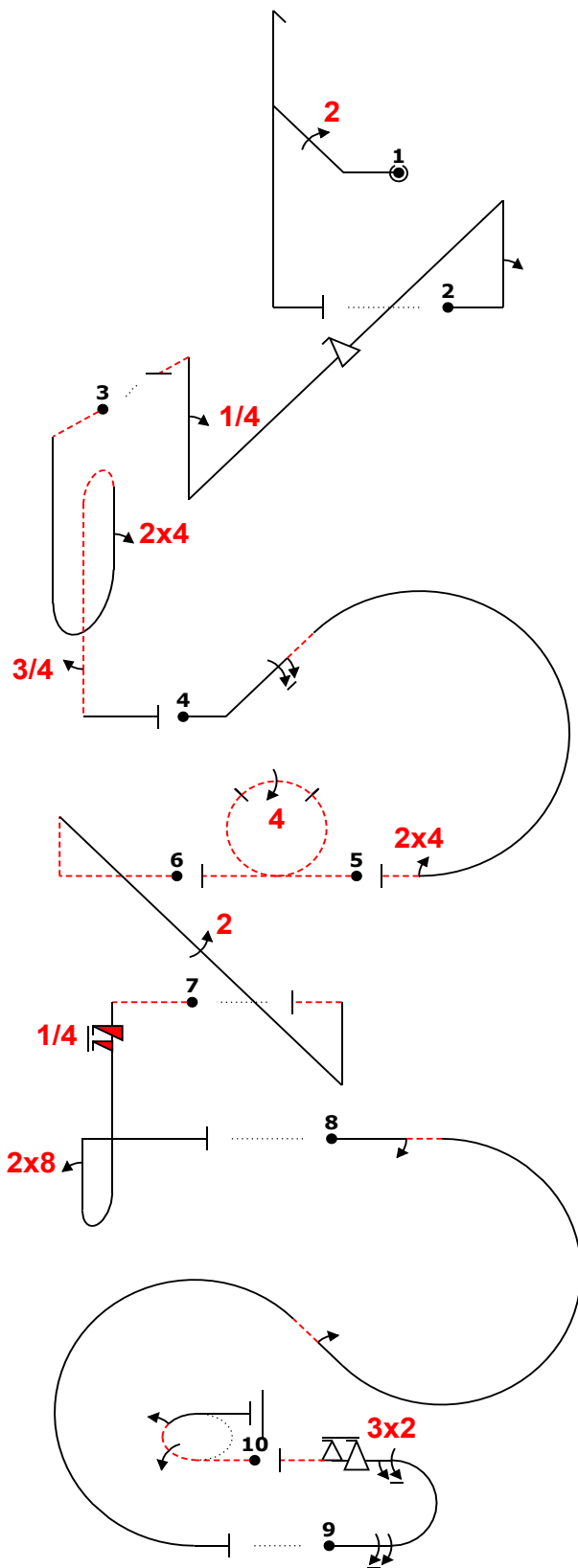
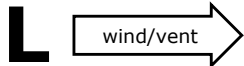

Figure K

320

Total K

350

Judges Name

Flight #

Signature

Number

Fig	Grade	Pos	Remarks
1	.		
2	.		
3	.		
4	.		
5	.		
6	.		
7	.		
8	.		
9	.		
10	.		

Positioning

30

.

Too Low

Trg Violation

Too High

Wing Rocks

Interruptions

Disqual Fig

Insertions

Other(note...)

/22dh... (-6,0) "@C" 2'pn(...'f....)'4'- (1,1) -...'ibpb(.....24).....3 20%6"rc24-
 "@D" -o44-pn(.....,22.....) (4,0) "@E"5is...ib',8'+ (-6,0) 18%2'iac'
 (-4,0) "@A" -1% 9m,|"32,6f- -3% "@B" -2jo15>

Fig 1	K	Fig 2 C	K	Fig 3	K	Fig 4	K	Fig 5 D	K	Fig 6	K	Fig 7 E	K	Fig 8	K	Fig 9 A	K	Fig 10 B	K
5.3.1.1	18	1.3.14.1	22	8.8.3.4	20	8.5.4.1	11	7.4.1.2	15	1.3.9.2	24	8.4.2.4	14	7.5.5.3	15	7.2.1.1	6	2.2.3.4	26
9.2.2.4	11	9.1.1.2	8	9.4.1.2	9	9.1.2.6	12	9.4.3.4	11	9.2.4.4	9	9.12.1.5	6	9.1.3.2	4	9.1.3.8	12		
		9.9.4.4	11	9.1.5.3	6	9.4.3.2	5					9.8.1.1	7	9.1.2.2	6	9.2.3.6	12		
		9.1.1.1	6													9.9.3.6	14		
	29		47		35		28		26		33		27		25		44		26

Pilot: Maxime ORTH

A/C: EA 330 SC FHLYK

Team: FRA



CIVA Advanced

Free Known

wind/vent ←

R

Figure K

320

Total K

350

Judges Name	
Signature	Number

Flight #

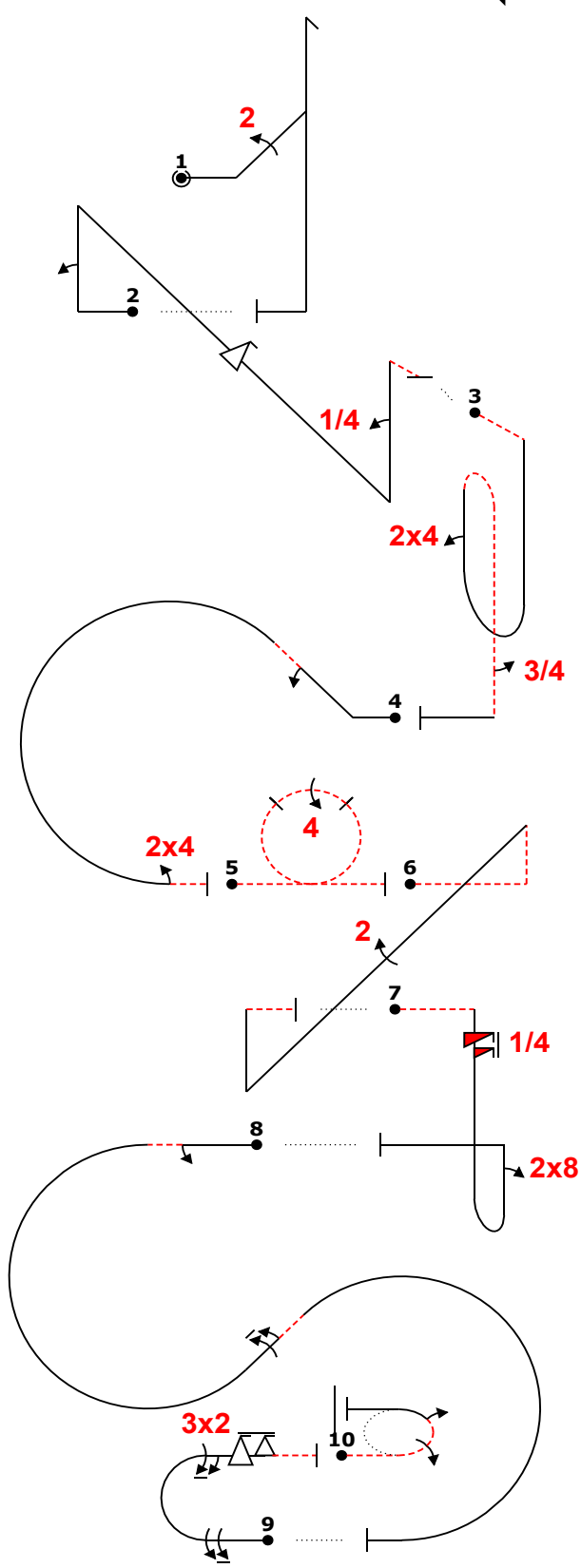

Fig	Grade	Pos	Remarks
1	.		
2	.		
3	.		
4	.		
5	.		
6	.		
7	.		
8	.		
9	.		
10	.		

Positioning 30 .

Too Low		Trg Violation	
Too High		Wing Rocks	
Interruptions		Disqual Fig	
Insertions		Other(note...)	

/22dh... (-6,0) "@C" 2'pn(...'f...)'4'- (1,1) -...'ibpb(.....24).....3 20% +.....2''rc24-
 "@D" -o44-pn(.....,22.....) (4,0) "@E" -...5is... 'ib'',8''+- (-6,0) 18%
 '6'''+..... (-4,0) "@A" -1% 9m,|"32,6f- -3% "@B" -2jo15>

Fig 1	K	Fig 2 C	K	Fig 3	K	Fig 4	K	Fig 5 D	K	Fig 6	K	Fig 7 E	K	Fig 8	K	Fig 9 A	K	Fig 10 B	K
5.3.1.1	18	1.3.14.1	22	8.8.3.4	20	8.5.4.1	11	7.4.1.2	15	1.3.9.2	24	8.4.2.4	14	7.5.5.3	15	7.2.1.1	6	2.2.3.4	26
9.2.2.4	11	9.1.1.2	8	9.4.1.2	9	9.1.2.2	6	9.4.3.4	11	9.2.4.4	9	9.12.1.5	6	9.1.3.2	4	9.1.3.8	12		
		9.9.4.4	11	9.1.5.3	6	9.4.3.2	5					9.8.1.1	7	9.1.2.6	12	9.2.3.6	12		
		9.1.1.1	6													9.9.3.6	14		
	29		47		35		22		26		33		27		31		44		26

Pilot: Adrien PICARD

A/C: Cap 231 FGRSL

Team: FRA



CIVA Advanced

Free Known

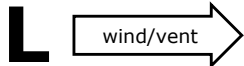

Figure K

320

Total K

350

Judges Name

Flight #

Signature

Number

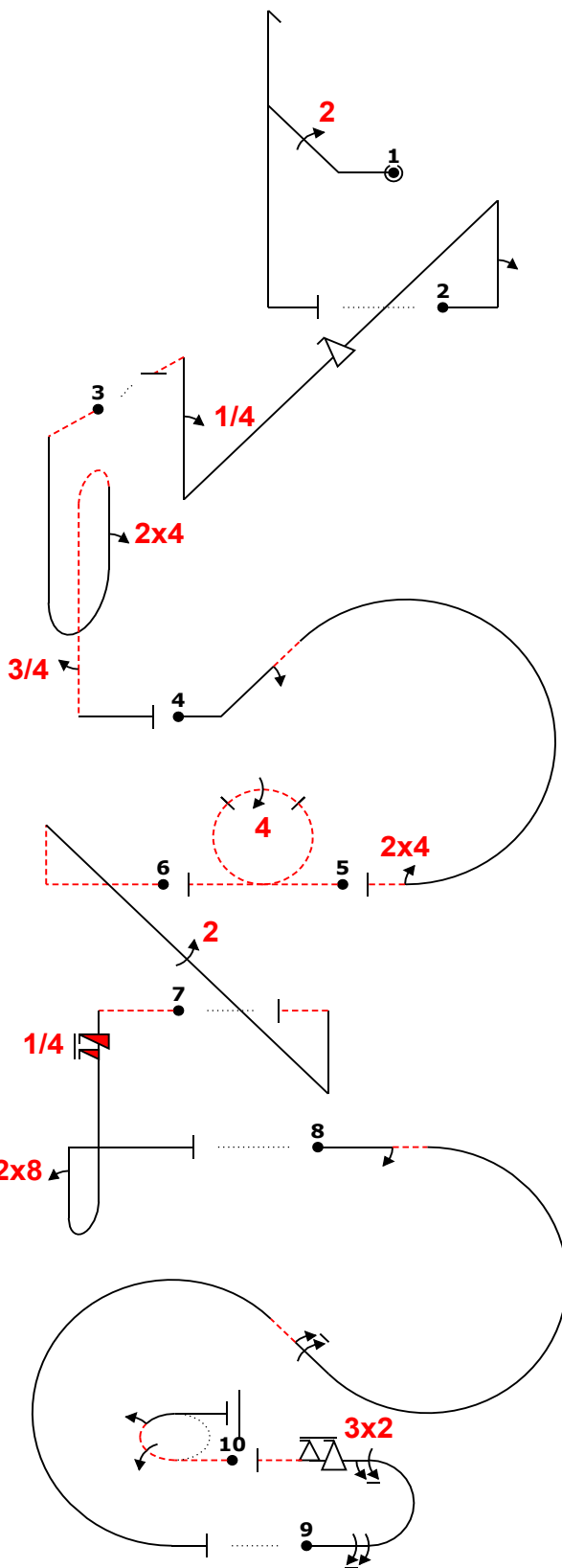

Fig	Grade	Pos	Remarks
1	.		
2	.		
3	.		
4	.		
5	.		
6	.		
7	.		
8	.		
9	.		
10	.		

Positioning

30

.

Too Low

Trg Violation

Too High

Wing Rocks

Interruptions

Disqual Fig

Insertions

Other(note...)

/22dh... (-6,0) "@C" 2'pn(...'f....)'4'- (1,1) -...'ibpb(.....24).....3 20% +.....2''rc24-
 "@D" -o44- pn(.....,22.....) (4,0) "@E" -...5is...ib',8''+ (-6,0) 18%
 '6'''+..... (-4,0) "@A" -1% 9m,|"32,6f- -3% "@B" -2jo15>

Fig 1	K	Fig 2 C	K	Fig 3	K	Fig 4	K	Fig 5 D	K	Fig 6	K	Fig 7 E	K	Fig 8	K	Fig 9 A	K	Fig 10 B	K
5.3.1.1	18	1.3.14.1	22	8.8.3.4	20	8.5.4.1	11	7.4.1.2	15	1.3.9.2	24	8.4.2.4	14	7.5.5.3	15	7.2.1.1	6	2.2.3.4	26
9.2.2.4	11	9.1.1.2	8	9.4.1.2	9	9.1.2.2	6	9.4.3.4	11	9.2.4.4	9	9.12.1.5	6	9.1.3.2	4	9.1.3.8	12		
		9.9.4.4	11	9.1.5.3	6	9.4.3.2	5					9.8.1.1	7	9.1.2.6	12	9.2.3.6	12		
		9.1.1.1	6													9.9.3.6	14		
	29		47		35		22		26		33		27		31		44		26

Pilot: Adrien PICARD

A/C: Cap 231 FGRSL

Team: FRA



CIVA Advanced

Free Known

wind/vent ←

R

Figure K

320

Total K

350

Judges Name

Flight #

Signature

Number

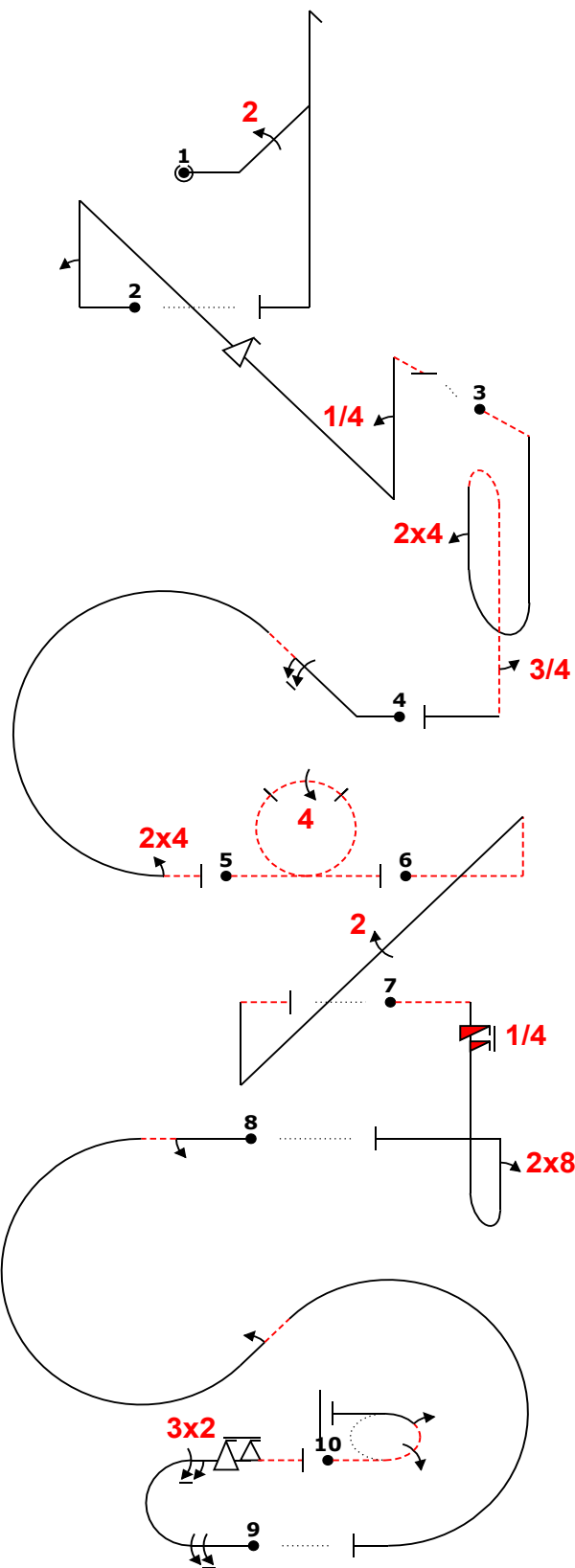

Fig	Grade	Pos	Remarks
1	.		
2	.		
3	.		
4	.		
5	.		
6	.		
7	.		
8	.		
9	.		
10	.		

Positioning

30

.

Too Low		Trg Violation	
Too High		Wing Rocks	
Interruptions		Disqual Fig	
Insertions		Other(note...)	

/22dh... (-6,0) "@C" 2'pn(...'f...)'4'- (1,1) -...'ibpb(.....24).....3 20%6"rc24-
 "@D" -o44-pn(...',22.....)' (4,0) "@E" -'5is... 'ib',8'+ (-6,0) 18%2'iac'
 '2'....)+ (-4,0) "@A" -1% 9m,|"32,6f- -3% "@B" -2jo15>

Fig 1	K	Fig 2 C	K	Fig 3	K	Fig 4	K	Fig 5 D	K	Fig 6	K	Fig 7 E	K	Fig 8	K	Fig 9 A	K	Fig 10 B	K
5.3.1.1	18	1.3.14.1	22	8.8.3.4	20	8.5.4.1	11	7.4.1.2	15	1.3.9.2	24	8.4.2.4	14	7.5.5.3	15	7.2.1.1	6	2.2.3.4	26
9.2.2.4	11	9.1.1.2	8	9.4.1.2	9	9.1.2.6	12	9.4.3.4	11	9.2.4.4	9	9.12.1.5	6	9.1.3.2	4	9.1.3.8	12		
		9.9.4.4	11	9.1.5.3	6	9.4.3.2	5					9.8.1.1	7	9.1.2.2	6	9.2.3.6	12		
		9.1.1.1	6													9.9.3.6	14		
	29		47		35		28		26		33		27		25		44		26

Pilot: Jérémy RENARD

A/C: Cap 232 FHKAP

Team: FRA



CIVA Advanced

Free Known

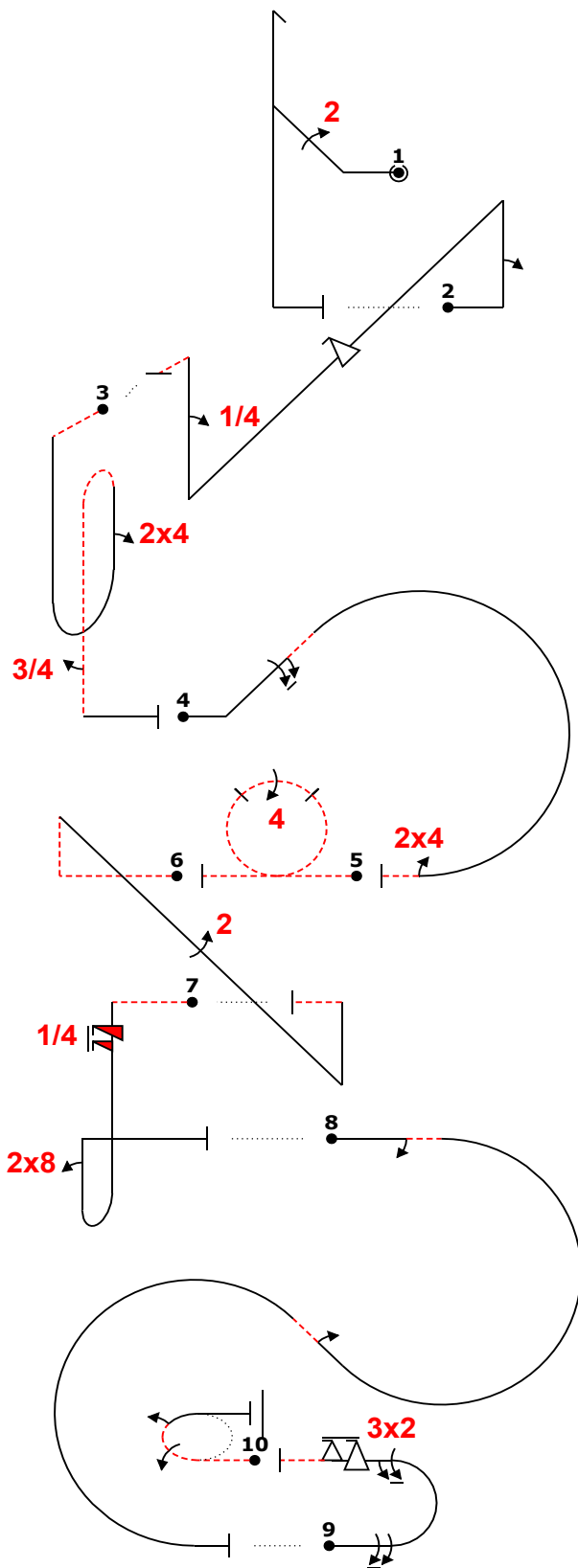
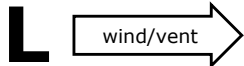

/22dh... (-6,0) "@C" 2'pn(...'f....)'4'- (1,1) -...'ibpb(.....24).....3 20% +.....6''rc24-
 "@D" -o44-pn(.....,22.....) (4,0) "@E" -...5is...ib',8''+- (-6,0) 18%2'iac'
 '2'''+..... (-4,0) "@A" -1% 9m,|"32,6f- -3% "@B" -2jo15>

Figure K

320

Total K

350

Judges Name

Flight #

Signature Number

Fig	Grade	Pos	Remarks
1	.		
2	.		
3	.		
4	.		
5	.		
6	.		
7	.		
8	.		
9	.		
10	.		

Positioning

30

.

Too Low		Trg Violation	
Too High		Wing Rocks	
Interruptions		Disqual Fig	
Insertions		Other(note...)	

Fig 1	K	Fig 2 C	K	Fig 3	K	Fig 4	K	Fig 5 D	K	Fig 6	K	Fig 7 E	K	Fig 8	K	Fig 9 A	K	Fig 10 B	K
5.3.1.1	18	1.3.14.1	22	8.8.3.4	20	8.5.4.1	11	7.4.1.2	15	1.3.9.2	24	8.4.2.4	14	7.5.5.3	15	7.2.1.1	6	2.2.3.4	26
9.2.2.4	11	9.1.1.2	8	9.4.1.2	9	9.1.2.6	12	9.4.3.4	11	9.2.4.4	9	9.12.1.5	6	9.1.3.2	4	9.1.3.8	12		
		9.9.4.4	11	9.1.5.3	6	9.4.3.2	5					9.8.1.1	7	9.1.2.2	6	9.2.3.6	12		
		9.1.1.1	6													9.9.3.6	14		
	29		47		35		28		26		33		27		25		44		26

Pilot: Jérémy RENARD

A/C: Cap 232 FHKAP

Team: FRA



CIVA Advanced

Free Known

wind/vent ←

R

Figure K

320

Total K

350

Judges Name	
Signature	Number

Flight #

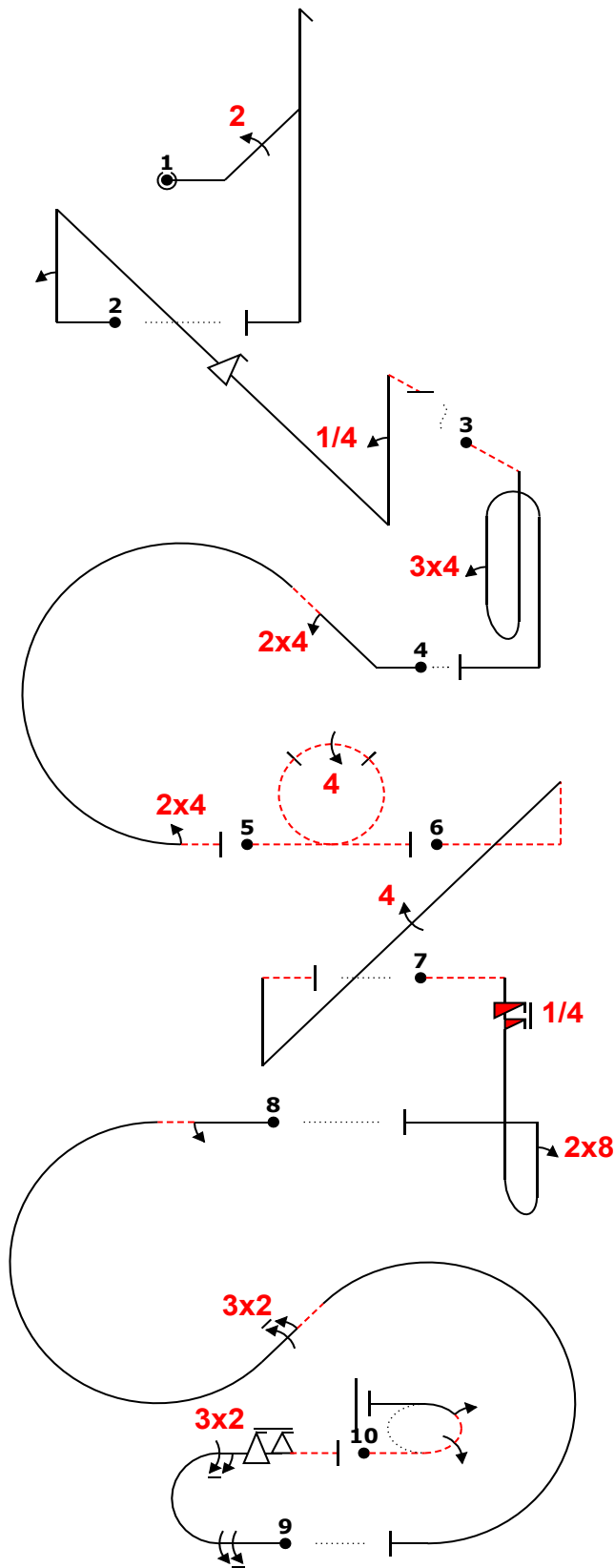

Fig	Grade	Pos	Remarks
1	.		
2	.		
3	.		
4	.		
5	.		
6	.		
7	.		
8	.		
9	.		
10	.		

Positioning 30 .

Too Low		Trg Violation	
Too High		Wing Rocks	
Interruptions		Disqual Fig	
Insertions		Other(note...)	

/22dh... ' (-6,0) "@C" 2'pn(...'f....)'4'- (0,2) --.ibb(.....34).. (1,0) 20% +24''rc24.....
 "@D" -044-pn(...',44.....)'' - (4,0) "@E"5is... 'ib',8''+~ (-6,0) 18%2'iac(
 ...32...)+ (-4,0) "@A" -1% 9m,|"32,6f- -3% "@B" -2jo15>

Fig 1	K	Fig 2 C	K	Fig 3	K	Fig 4	K	Fig 5 D	K	Fig 6	K	Fig 7 E	K	Fig 8	K	Fig 9 A	K	Fig 10 B	K
5.3.1.1	18	1.3.14.1	22	8.8.1.4	18	8.5.4.1	11	7.4.1.2	15	1.3.9.2	24	8.4.2.4	14	7.5.5.3	15	7.2.1.1	6	2.2.3.4	26
9.2.2.4	11	9.1.1.2	8	9.4.1.3	12	9.4.2.2	7	9.4.3.4	11	9.4.4.4	11	9.12.1.5	6	9.1.3.2	4	9.1.3.8	12		
		9.9.4.4	11			9.4.3.2	5					9.8.1.1	7	9.2.2.6	14	9.2.3.6	12		
		9.1.1.1	6													9.9.3.6	14		
	29		47		30		23		26		35		27		33		44		26

Pilot: Margaux TAHAR

A/C: EA 330 SC DEXB

Team: FRA

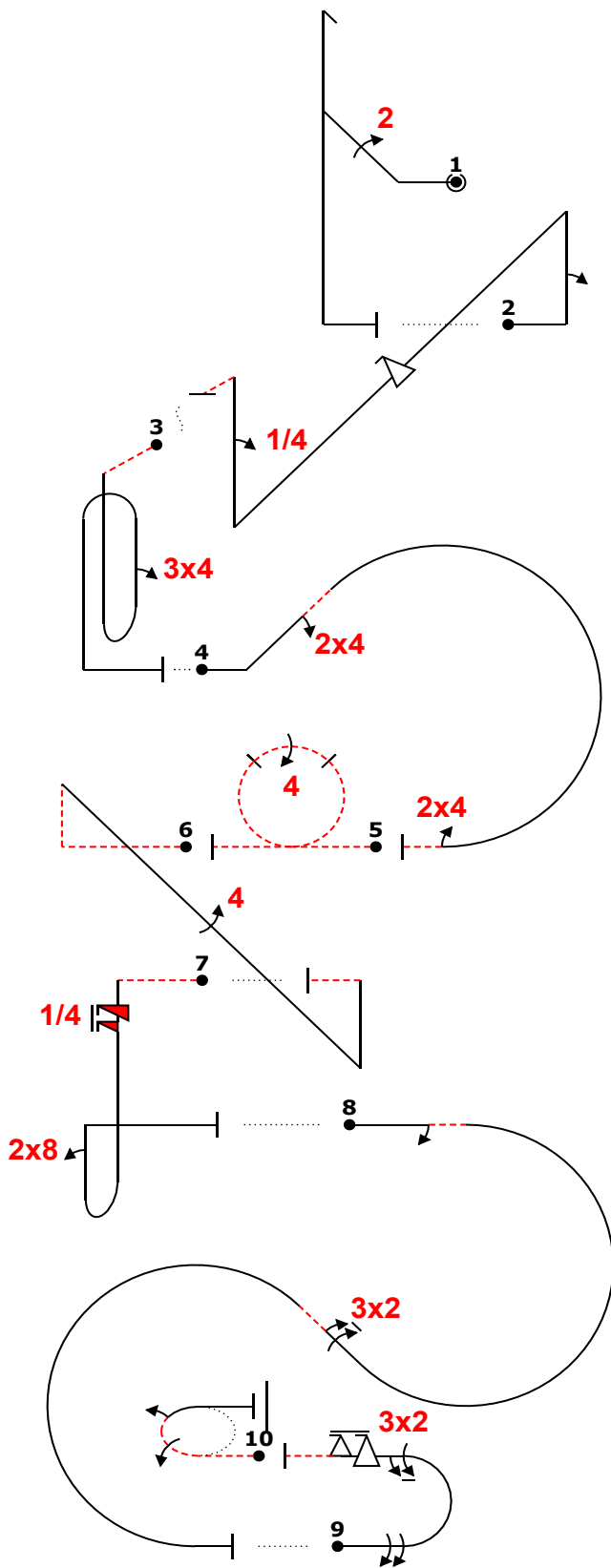
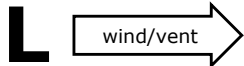

/22dh... (-6,0) "@C" 2'pn(...'f....)'4'- (0,2) --.ibb(.....34).. (1,0) 20%24...rc24...
 "@D" -044-pn(...',44.....) - (4,0) "@E"5is... 'ib',8' +~ (-6,0) 18%2'iac(
 ...32...)+ (-4,0) "@A" -1% 9m,|"32,6f- -3% "@B" -2jo15>

Fig	Grade	Pos	Remarks
1	.		
2	.		
3	.		
4	.		
5	.		
6	.		
7	.		
8	.		
9	.		
10	.		

Positioning	30	.
-------------	----	---

Too Low		Trg Violation	
Too High		Wing Rocks	
Interruptions		Disqual Fig	
Insertions		Other(note...)	

Fig 1	K	Fig 2 C	K	Fig 3	K	Fig 4	K	Fig 5 D	K	Fig 6	K	Fig 7 E	K	Fig 8	K	Fig 9 A	K	Fig 10 B	K
5.3.1.1	18	1.3.14.1	22	8.8.1.4	18	8.5.4.1	11	7.4.1.2	15	1.3.9.2	24	8.4.2.4	14	7.5.5.3	15	7.2.1.1	6	2.2.3.4	26
9.2.2.4	11	9.1.1.2	8	9.4.1.3	12	9.4.2.2	7	9.4.3.4	11	9.4.4.4	11	9.12.1.5	6	9.1.3.2	4	9.1.3.8	12		
		9.9.4.4	11			9.4.3.2	5					9.8.1.1	7	9.2.2.6	14	9.2.3.6	12		
		9.1.1.1	6													9.9.3.6	14		
	29		47		30		23		26		35		27		33		44		26

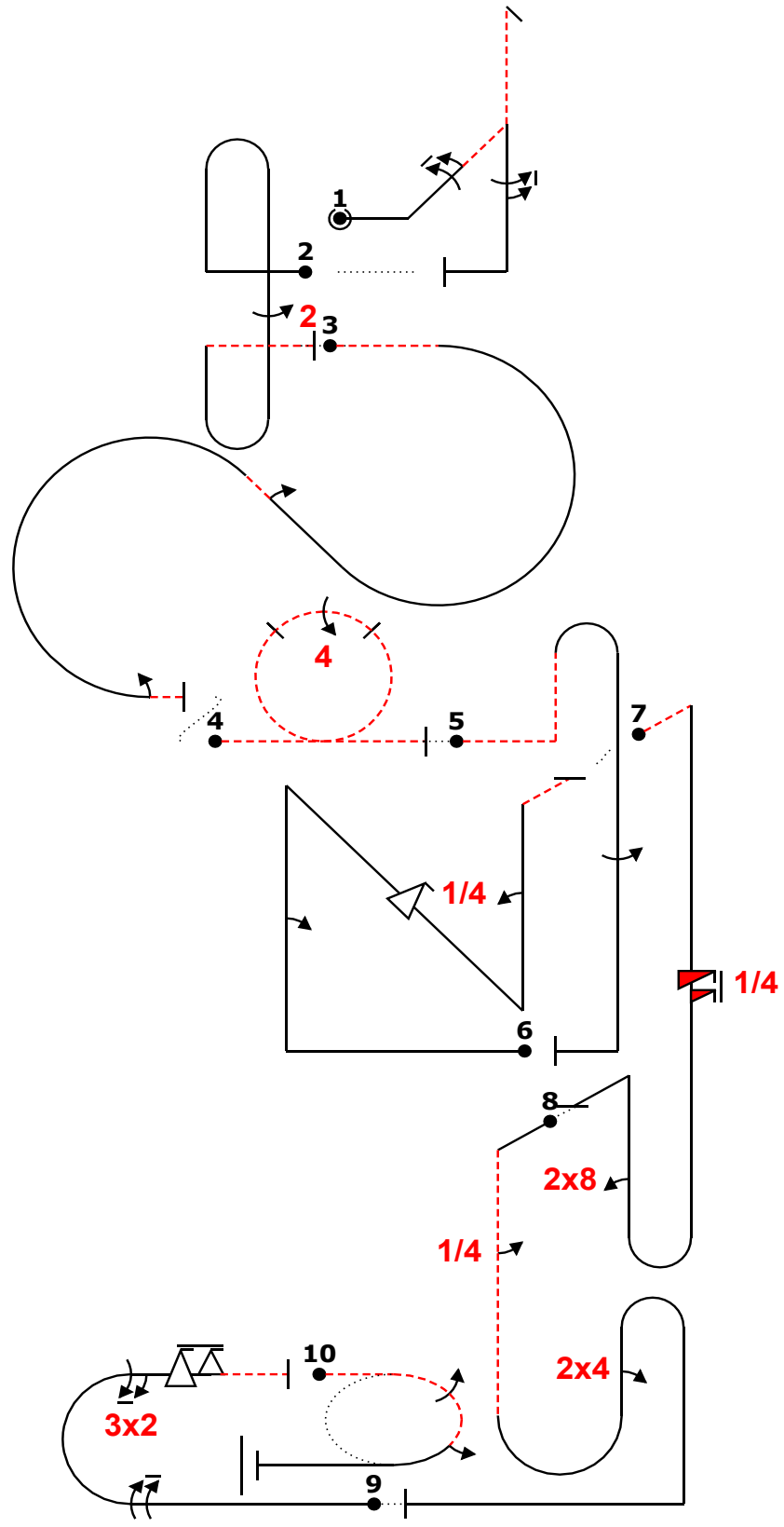
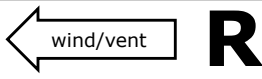

Fig	Grade	Pos	Remarks
1	.		
2	.		
3	.		
4	.		
5	.		
6	.		
7	.		
8	.		
9	.		
10	.		

Positioning
30

Too Low		Trg Violation	
Too High		Wing Rocks	
Interruptions		Disqual Fig	
Insertions		Other(note...)	

```
/6dh6. (-5,0) 'bb(22.)'~ [-3,0] 12% ~~~~~ iac(,"|2")2- (-2,3) "@D" 1% -o44- (-2,0) ~'b
... '1...+' "@C" /~+~+. '2.pn(.f..)' '4'~^ (1,-1) "E" .....5is.....'ib`8. (2,-1) '+' "4....'ibb(
;|"24')...++++> (2,0) "A" 1% ....,9m,32,6f- "@B" 1% /~2jo15~
```

Fig 1	K	Fig 2	K	Fig 3	K	Fig 4 D	K	Fig 5	K	Fig 6 C	K	Fig 7 E	K	Fig 8	K	Fig 9 A	K	Fig 10 B	K
5.3.2.1	24	8.8.1.1	18	7.5.7.4	15	7.4.1.2	15	8.4.4.2	14	1.3.14.1	22	8.4.2.4	14	8.8.8.3	19	7.2.1.1	6	2.2.3.4	26
9.1.2.6	12	9.2.5.4	9	9.1.2.2	6	9.4.3.4	11	9.1.5.4	8	9.1.1.2	8	9.12.1.5	6	9.1.5.1	2	9.1.3.8	12		
9.1.5.6	10			9.1.3.2	4					9.9.4.4	11	9.8.1.1	7	9.4.1.2	9	9.2.3.6	12		
										9.1.1.1	6					9.9.3.6	14		
	46		27		25		26		22		47		27		30		44		26

Figure K
320
Total K
350

Judges Name	
Signature	Number

Flight #

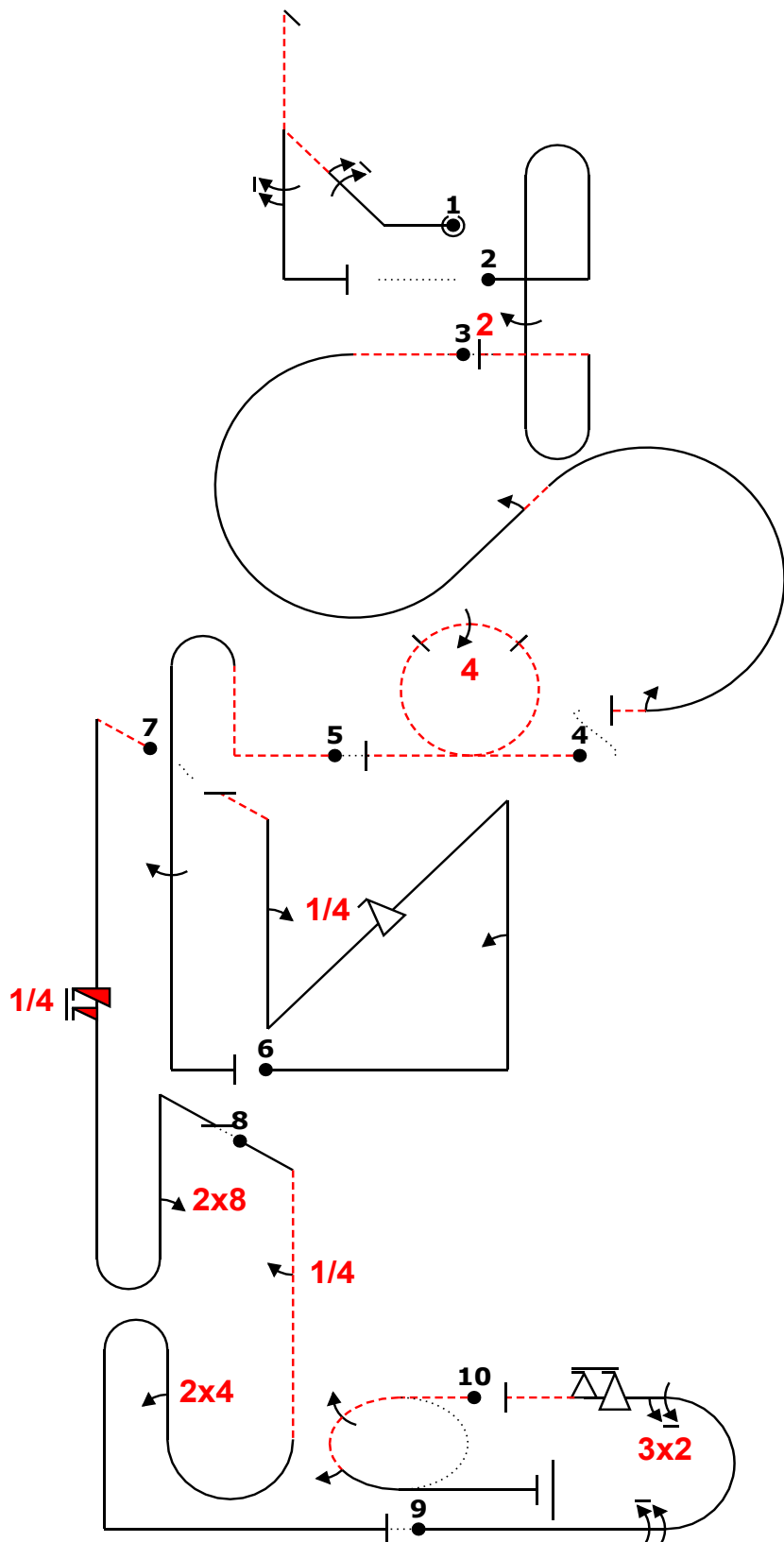
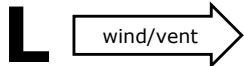

/6dh6. (-5,0) 'bb(22.)'~ [-3,0] 12% ~~~~~ iac(,"|2")2- (-2,3) "@D" 1% -o44- (-2,0) ~'b
...1...+)'@C' /~+~+. '2.pn(.f..)'4'~^ (1,-1) "E" ~~~~~5is.....'ib'8. (2,-1) '+''|4....'ibb(~~~~~
,|"24')...++++> (2,0) "@A" 1%,9m,32,6f- "@B" 1% /~2jo15~

Fig	Grade	Pos	Remarks
1	.		
2	.		
3	.		
4	.		
5	.		
6	.		
7	.		
8	.		
9	.		
10	.		

Positioning
30

Too Low		Trg Violation	
Too High		Wing Rocks	
Interruptions		Disqual Fig	
Insertions		Other(note...)	

Fig 1	K	Fig 2	K	Fig 3	K	Fig 4 D	K	Fig 5	K	Fig 6 C	K	Fig 7 E	K	Fig 8	K	Fig 9 A	K	Fig 10 B	K
5.3.2.1	24	8.8.1.1	18	7.5.7.4	15	7.4.1.2	15	8.4.4.2	14	1.3.14.1	22	8.4.2.4	14	8.8.8.3	19	7.2.1.1	6	2.2.3.4	26
9.1.2.6	12	9.2.5.4	9	9.1.2.2	6	9.4.3.4	11	9.1.5.4	8	9.1.1.2	8	9.12.1.5	6	9.1.5.1	2	9.1.3.8	12		
9.1.5.6	10			9.1.3.2	4					9.9.4.4	11	9.8.1.1	7	9.4.1.2	9	9.2.3.6	12		
										9.1.1.1	6					9.9.3.6	14		
	46		27		25		26		22		47		27		30		44		26



CIVA Advanced 05.09.2024
Free Known EAAC LRCN

wind/vent ← **R**

Figure K
320
Total K
350

Judges Name
Signature
Number

Flight #

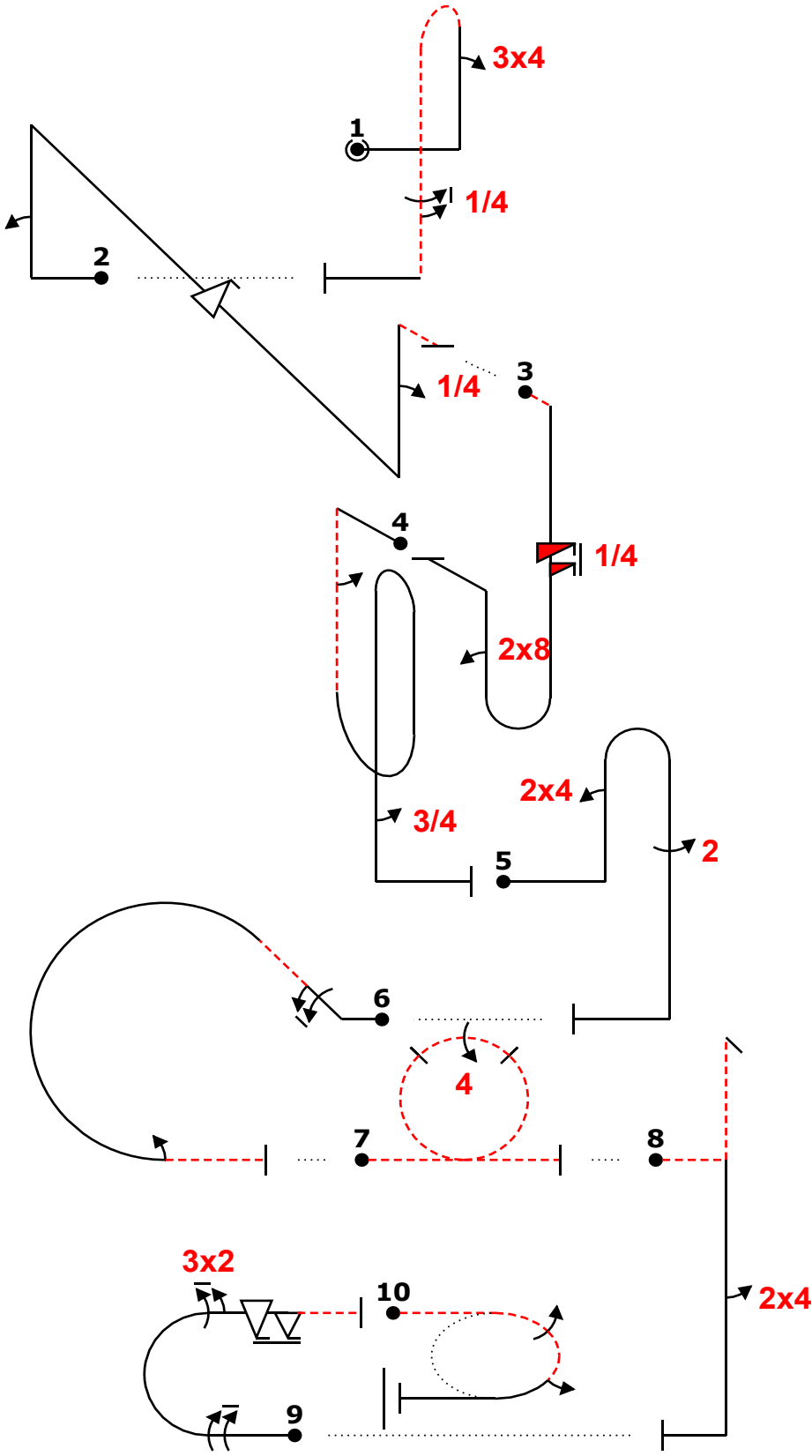

Fig	Grade	Pos	Remarks
1	.		
2	.		
3	.		
4	.		
5	.		
6	.		
7	.		
8	.		
9	.		
10	.		

Positioning
30 .

Too Low		Trg Violation	
Too High		Wing Rocks	
Interruptions		Disqual Fig	
Insertions		Other(note...)	

„34pb.'5 (-10,0) "@C" /2pn(...'f....),4- (2,1) "@E"5is..ib""|"8 2..iBb(.....)'3 24b22..' (-8,0) 11%6' rc2..... (2,0) "@D" -o44- (2,0) -h..'24...' (-19,0) "@A" ,9m32,6f- "@B" -2jo15

Fig 1	K	Fig 2 C	K	Fig 3 E	K	Fig 4	K	Fig 5	K	Fig 6	K	Fig 7 D	K	Fig 8	K	Fig 9 A	K	Fig 10 B	K
8.4.3.1	15	1.3.14.1	22	8.4.2.4	14	8.8.8.3	19	8.4.1.1	13	8.5.4.1	11	7.4.1.2	15	5.2.1.4	22	7.2.1.1	6	2.2.3.4	26
9.4.1.3	12	9.1.1.2	8	9.12.1.5	6	9.1.5.2	4	9.4.1.2	9	9.1.2.6	12	9.4.3.4	11	9.4.5.2	5	9.1.3.8	12		
9.1.5.5	9	9.9.4.4	11	9.8.1.1	7	9.1.5.3	6	9.2.5.4	9	9.1.3.2	4					9.2.3.6	12		
		9.1.1.1	6													9.9.3.6	14		
	36		47		27		29		31		27		26		27		44		26

Pilot: Balázs Kiss

A/C: Extra300 D-EEXT

Team: HUN



Figure K
320
Total K
350

Judges Name	
Signature	Number

Flight #

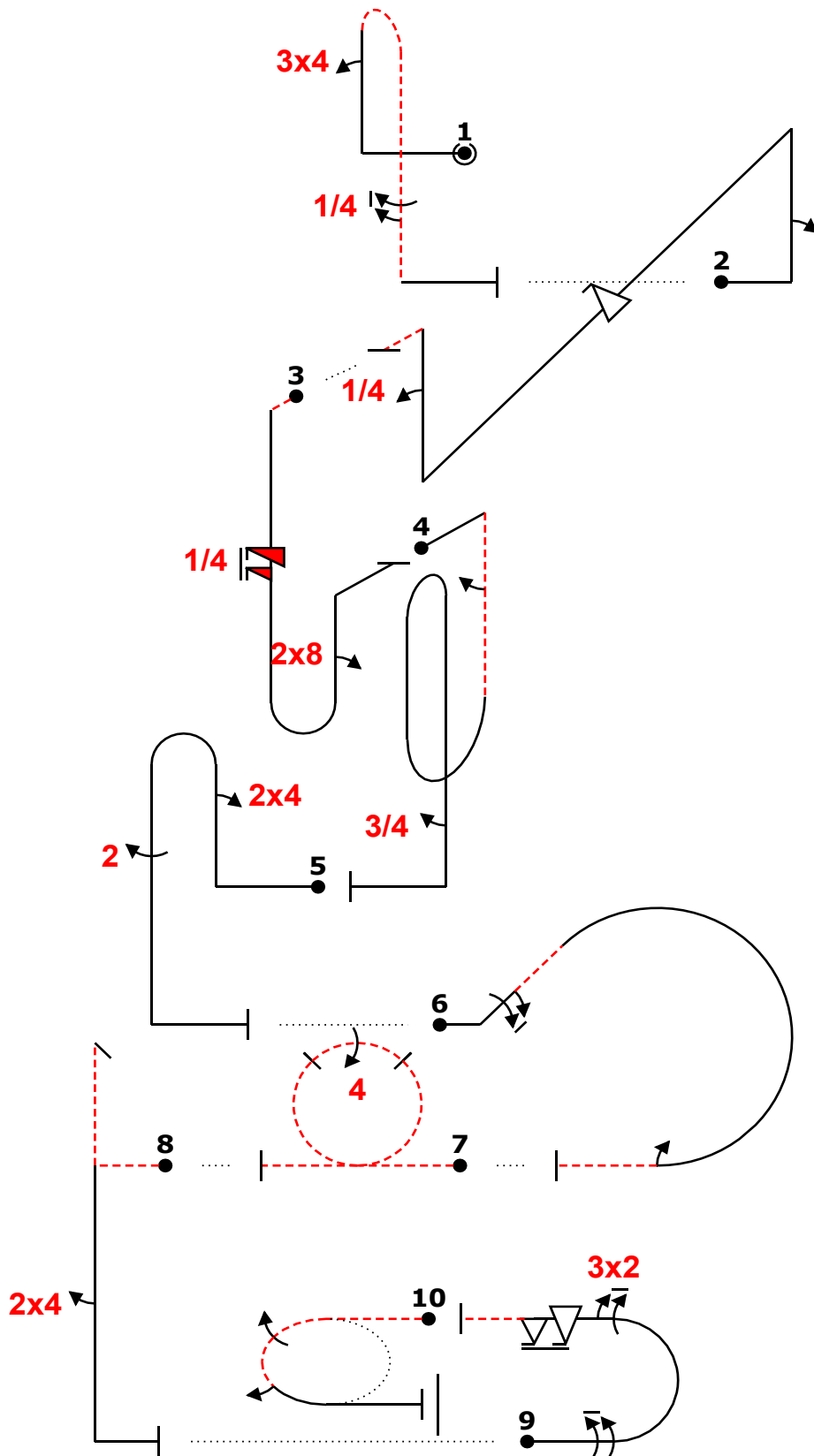
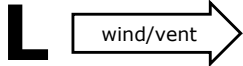

„34pb.'5 (-10,0) "@C" /2pn(...'f....),4- (2,1) "@E"5is..ib""|"8 2..iBb(.....).....'3 24b22..' (-8,0) 11%6' rc2..... (2,0) "@D" -o44- (2,0) -h..'24...' (-19,0) "@A" ,9m32,6f- "@B" -2jo15

Fig	Grade	Pos	Remarks
1	.		
2	.		
3	.		
4	.		
5	.		
6	.		
7	.		
8	.		
9	.		
10	.		

Positioning
30

Too Low		Trg Violation	
Too High		Wing Rocks	
Interruptions		Disqual Fig	
Insertions		Other(note...)	

Fig 1	K	Fig 2 C	K	Fig 3 E	K	Fig 4	K	Fig 5	K	Fig 6	K	Fig 7 D	K	Fig 8	K	Fig 9 A	K	Fig 10 B	K
8.4.3.1	15	1.3.14.1	22	8.4.2.4	14	8.8.8.3	19	8.4.1.1	13	8.5.4.1	11	7.4.1.2	15	5.2.1.4	22	7.2.1.1	6	2.2.3.4	26
9.4.1.3	12	9.1.1.2	8	9.12.1.5	6	9.1.5.2	4	9.4.1.2	9	9.1.2.6	12	9.4.3.4	11	9.4.5.2	5	9.1.3.8	12		
9.1.5.5	9	9.9.4.4	11	9.8.1.1	7	9.1.5.3	6	9.2.5.4	9	9.1.3.2	4					9.2.3.6	12		
		9.1.1.1	6													9.9.3.6	14		
	36		47		27		29		31		27		26		27		44		26

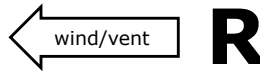

Figure K
320
Total K
350

Judges Name	
Signature	Number

Flight #

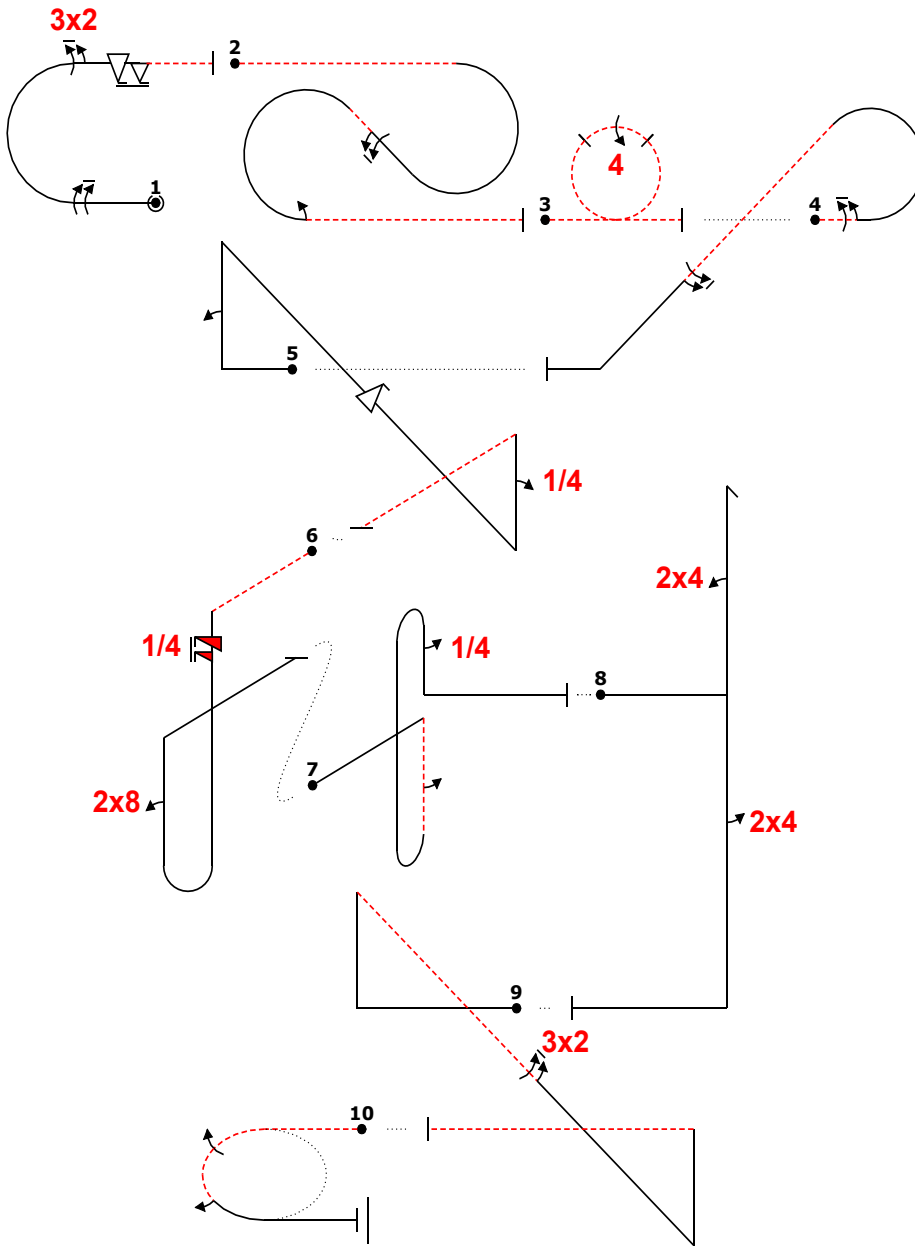

Fig	Grade	Pos	Remarks
1	.		
2	.		
3	.		
4	.		
5	.		
6	.		
7	.		
8	.		
9	.		
10	.		

Positioning
30

Too Low		Trg Violation	
Too High		Wing Rocks	
Interruptions		Disqual Fig	
Insertions		Other(note...)	

ed "@A" 5% /,9m32,6f- 4% -"iac(6')2-" "@D" -o44- (8,0) 2% -".....6'c.....6 (-19,0) "@C" /~'2pn(...'f...
...'),4----- (-1,0) "@E" 1% ~~~~~',5is.....'ib'8'++++ (-2,13) ~+++2.ibb(.'4)++~ (-1,0) ~+...24.'h..'24.....'
+++ (-1,0) ~+++n(.....'32.....')----- (-2,0) "@B" 4% -2jo15

Fig 1 A	K	Fig 2	K	Fig 3 D	K	Fig 4	K	Fig 5 C	K	Fig 6 E	K	Fig 7	K	Fig 8	K	Fig 9	K	Fig 10 B	K
7.2.1.1	6	7.5.7.4	15	7.4.1.2	15	8.5.8.2	11	1.3.14.1	22	8.4.2.4	14	8.8.8.3	19	5.2.1.1	17	1.3.11.1	20	2.2.3.4	26
9.1.3.8	12	9.1.2.6	12	9.4.3.4	11	9.1.3.6	10	9.1.1.2	8	9.12.1.5	6	9.1.5.2	4	9.4.1.2	9	9.2.4.6	12		
9.2.3.6	12	9.1.3.2	4			9.1.4.6	10	9.9.4.4	11	9.8.1.1	7	9.1.5.1	2	9.4.5.2	5				
9.9.3.6	14					9.1.1.1	6												
	44		31		26		31		47		27		25		31		32		26



Figure K
320
Total K
350

Judges Name	
Signature	Number

Flight #

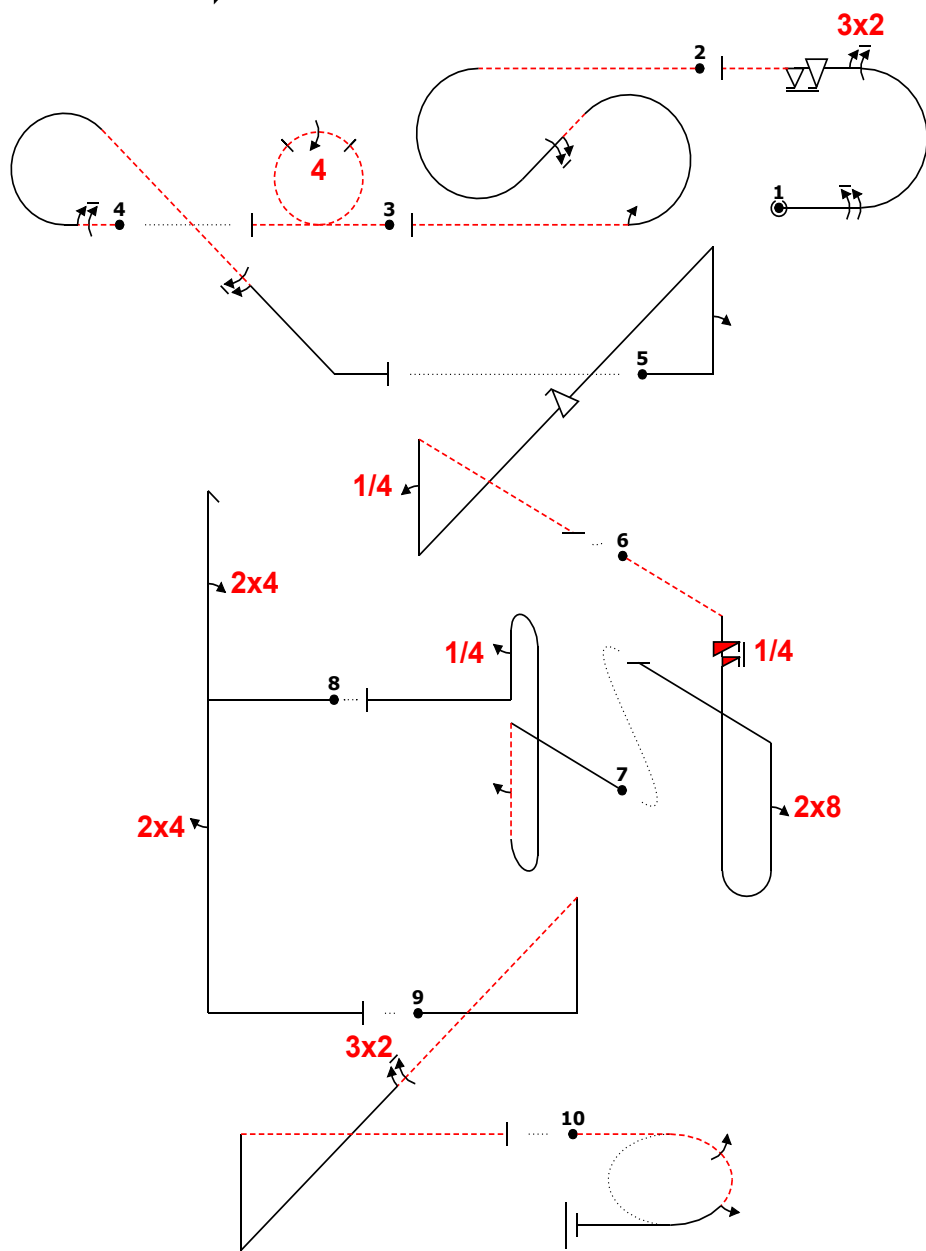
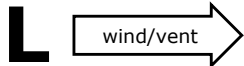

Fig	Grade	Pos	Remarks
1	.		
2	.		
3	.		
4	.		
5	.		
6	.		
7	.		
8	.		
9	.		
10	.		

Positioning
30

Too Low		Trg Violation	
Too High		Wing Rocks	
Interruptions		Disqual Fig	
Insertions		Other(note...)	

ed "@A" 5% /,9m32,6f- 4% -" iac(6')2-" "@D" -o44- (8,0) 2% -" 6'c....6 (-19,0) "@C" /~'2pn(...'f...
...'),4----- (-1,0) "@E" 1% ~~~~~,5is.....'ib'8'++++ (-2,13) ~~~~'2.ibb(.'')4+++ (-1,0) ~~~..24.'h..'24.....'
++++ (-1,0) ~~~~n(.....'32.....')----- (-2,0) "@B" 4% -2jo15

Fig 1 A	K	Fig 2	K	Fig 3 D	K	Fig 4	K	Fig 5 C	K	Fig 6 E	K	Fig 7	K	Fig 8	K	Fig 9	K	Fig 10 B	K
7.2.1.1	6	7.5.7.4	15	7.4.1.2	15	8.5.8.2	11	1.3.14.1	22	8.4.2.4	14	8.8.8.3	19	5.2.1.1	17	1.3.11.1	20	2.2.3.4	26
9.1.3.8	12	9.1.2.6	12	9.4.3.4	11	9.1.3.6	10	9.1.1.2	8	9.12.1.5	6	9.1.5.2	4	9.4.1.2	9	9.2.4.6	12		
9.2.3.6	12	9.1.3.2	4			9.1.4.6	10	9.9.4.4	11	9.8.1.1	7	9.1.5.1	2	9.4.5.2	5				
9.9.3.6	14							9.1.1.1	6										
	44		31		26		31		47		27		25		31		32		26

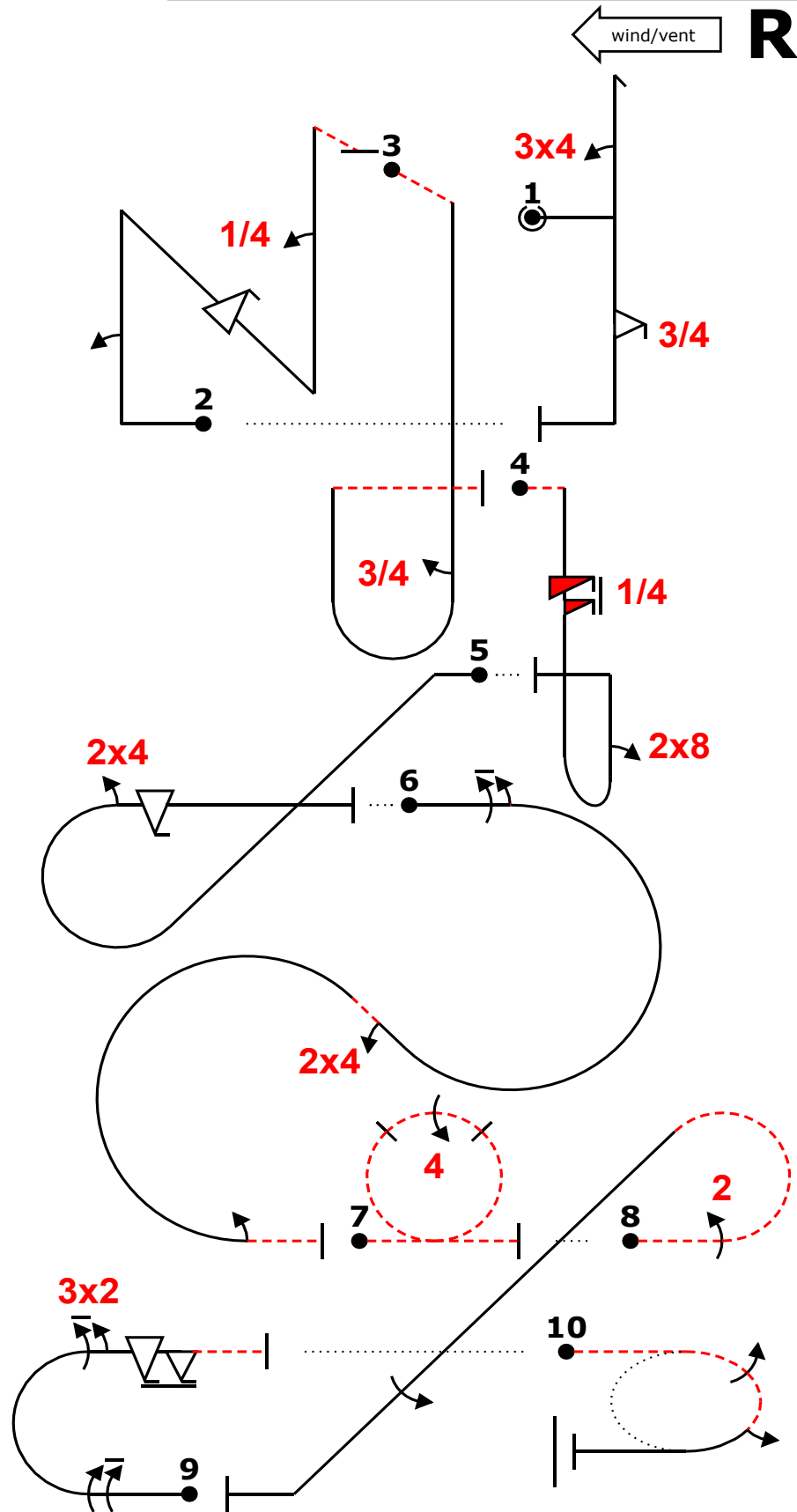

Fig	Grade	Pos	Remarks
1	.		
2	.		
3	.		
4	.		
5	.		
6	.		
7	.		
8	.		
9	.		
10	.		

Positioning
30 .

Too Low		Trg Violation	
Too High		Wing Rocks	
Interruptions		Disqual Fig	
Insertions		Other(note...)	

34h' '3f. (-14,0) "@C" /'2'pn(f'').4' - 6%',3'ib'.....> "@E"5is..ib'.....,8+` (1,0) `+...irc24,f+
 (-1,0) 10%6iac('24'')2- "@D" -1% ""-o44" (2,0) -1%22c.....'1
 "@A" ,9m32,6f- (12,0) "@B" -2jo15

Fig 1	K	Fig 2 C	K	Fig 3	K	Fig 4 E	K	Fig 5	K	Fig 6	K	Fig 7 D	K	Fig 8	K	Fig 9 A	K	Fig 10 B	K
5.2.1.1	17	1.3.14.1	22	8.4.1.4	13	8.4.2.4	14	8.5.3.3	10	7.5.8.3	15	7.4.1.2	15	8.5.5.2	12	7.2.1.1	6	2.2.3.4	26
9.4.1.3	12	9.1.1.2	8	9.1.5.3	6	9.12.1.5	6	9.4.3.2	5	9.1.3.6	10	9.4.3.4	11	9.2.3.4	9	9.1.3.8	12		
9.9.5.3	11	9.9.4.4	11			9.8.1.1	7	9.9.3.4	11	9.4.2.2	7			9.1.4.4	8	9.2.3.6	12		
		9.1.1.1	6							9.1.3.2	4					9.9.3.6	14		
	40		47		19		27		26		36		26		29		44		26



CIVA Advanced

Free Known

Figure K

320

Total K

350

Judges Name

Flight #

Signature

Number

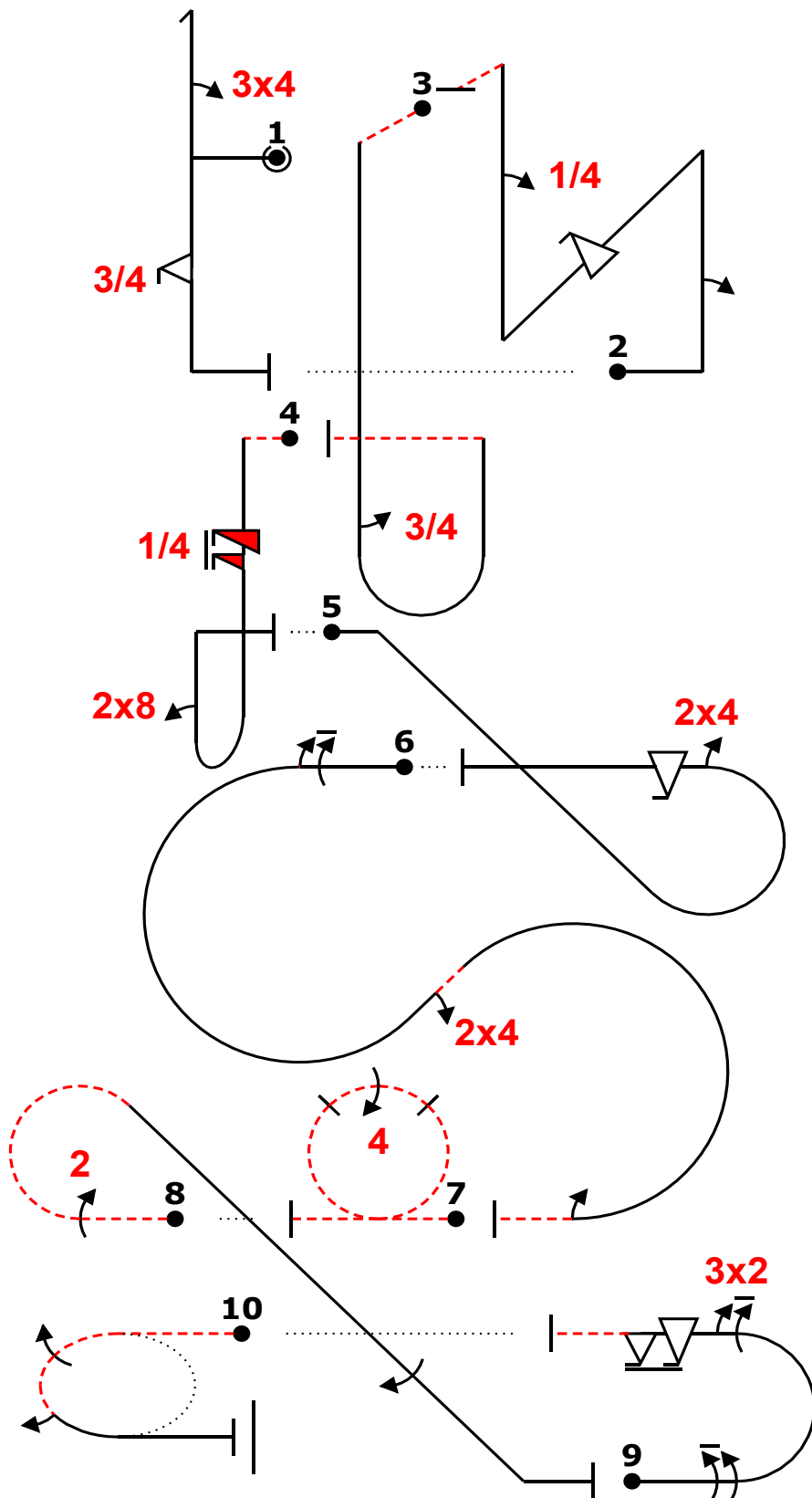
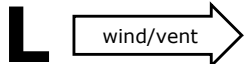

Fig	Grade	Pos	Remarks
1	.		
2	.		
3	.		
4	.		
5	.		
6	.		
7	.		
8	.		
9	.		
10	.		

Positioning

30

.

Too Low

Trg Violation

Too High

Wing Rocks

Interruptions

Disqual Fig

Insertions

Other(note...)

34h'3f. (-14,0) "@C" /'2'pn(f'')4' - 6%',3'ib'.....> "@E"5is..ib'.....,8+'' (1,0) '+..irc24,f+
 (-1,0) 10%6iac(''24''')2-....." @D" -1% ""-o44- (2,0) -1%22c.....'1
 "@A" ,9m32,6f- (12,0) "@B" -2jo15

Fig 1	K	Fig 2 C	K	Fig 3	K	Fig 4 E	K	Fig 5	K	Fig 6	K	Fig 7 D	K	Fig 8	K	Fig 9 A	K	Fig 10 B	K
5.2.1.1	17	1.3.14.1	22	8.4.1.4	13	8.4.2.4	14	8.5.3.3	10	7.5.8.3	15	7.4.1.2	15	8.5.5.2	12	7.2.1.1	6	2.2.3.4	26
9.4.1.3	12	9.1.1.2	8	9.1.5.3	6	9.12.1.5	6	9.4.3.2	5	9.1.3.6	10	9.4.3.4	11	9.2.3.4	9	9.1.3.8	12		
9.9.5.3	11	9.9.4.4	11			9.8.1.1	7	9.9.3.4	11	9.4.2.2	7			9.1.4.4	8	9.2.3.6	12		
		9.1.1.1	6							9.1.3.2	4					9.9.3.6	14		
	40		47		19		27		26		36		26		29		44		26

Pilot: Andrea Pesenato

A/C: CAP 231 F-GVFF

Team: ITA

wind/vent ← **R**

Figure K
320
Total K
350

Judges Name
Signature

Flight #
Number

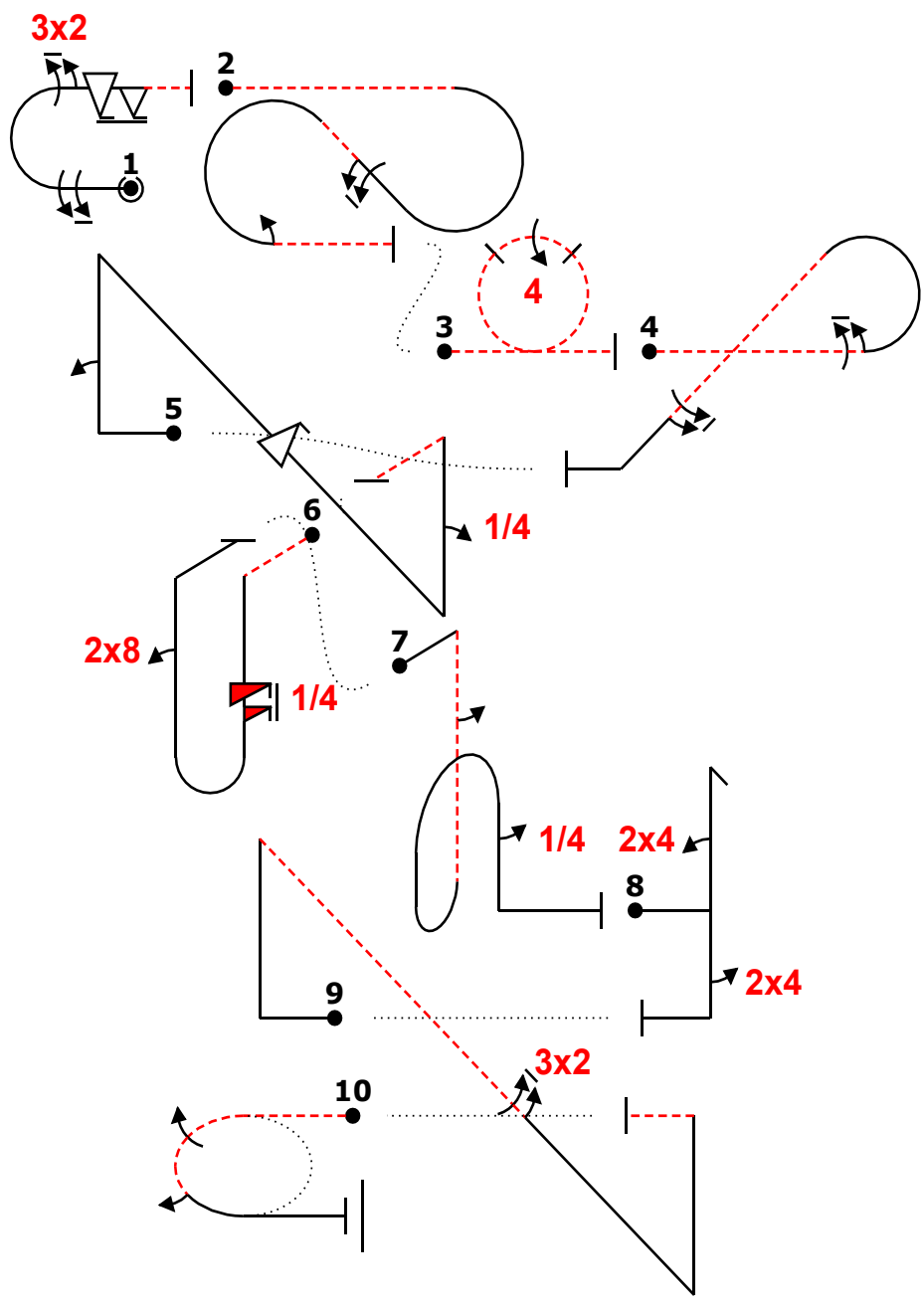

Fig	Grade	Pos	Remarks
1	.		
2	.		
3	.		
4	.		
5	.		
6	.		
7	.		
8	.		
9	.		
10	.		

Positioning
30

Too Low		Trg Violation	
Too High		Wing Rocks	
Interruptions		Disqual Fig	
Insertions		Other(note...)	

ed -3% "@A" 9m32,6f- -iic(6)2- -(-1,6) -2% "@D" -o44- -2% -6c...6" (-19,-2) "@C" 2pn(...'f...)',4-- (0,1) "@E" -5isib8 (6,9) +2...'ibB(''4 24h24 (-14,0) n(....'32....')- (-12,0) "@B" -2jo15

Fig 1 A	K	Fig 2	K	Fig 3 D	K	Fig 4	K	Fig 5 C	K	Fig 6 E	K	Fig 7	K	Fig 8	K	Fig 9	K	Fig 10 B	K
7.2.1.1	6	7.5.7.4	15	7.4.1.2	15	8.5.8.2	11	1.3.14.1	22	8.4.2.4	14	8.8.8.3	19	5.2.1.1	17	1.3.11.1	20	2.2.3.4	26
9.1.3.8	12	9.1.2.6	12	9.4.3.4	11	9.1.3.6	10	9.1.1.2	8	9.12.1.5	6	9.1.5.2	4	9.4.1.2	9	9.2.4.6	12		
9.2.3.6	12	9.1.3.2	4			9.1.4.6	10	9.9.4.4	11	9.8.1.1	7	9.1.5.1	2	9.4.5.2	5				
9.9.3.6	14							9.1.1.1	6										
	44		31		26		31		47		27		25		31		32		26

Pilot: Wojciech Kotulski

A/C: Extra NG SP-ING

Team: POL



CIVA Advanced

Free Known

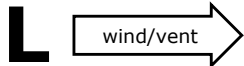

Figure K

320

Total K

350

Judges Name

Flight #

Signature

Number

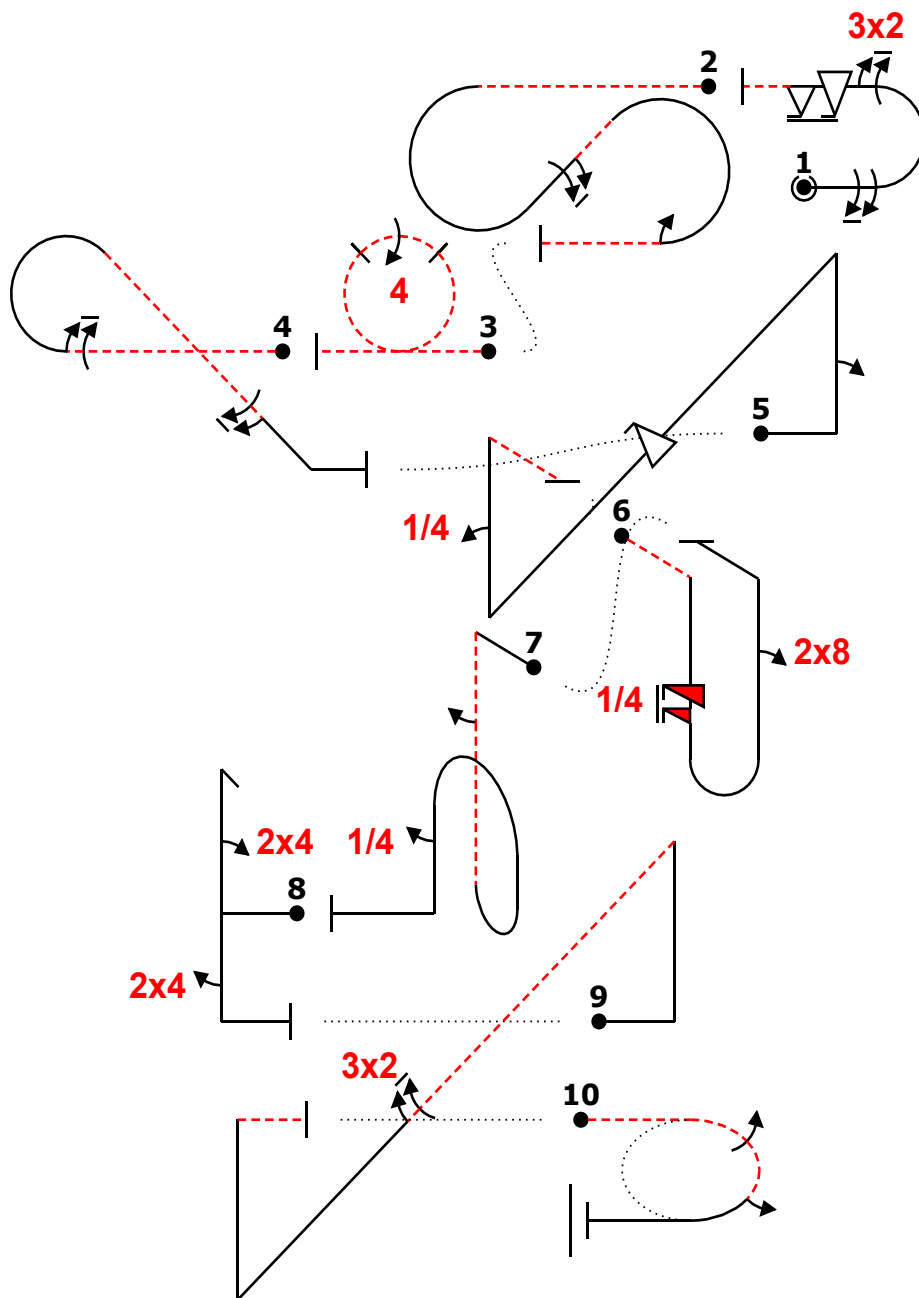

Fig	Grade	Pos	Remarks
1	.		
2	.		
3	.		
4	.		
5	.		
6	.		
7	.		
8	.		
9	.		
10	.		

Positioning

30

.

Too Low

Trg Violation

Too High

Wing Rocks

Interruptions

Disqual Fig

Insertions

Other(note...)

ed -3% "@A" 9m32,6f- -i ac(6)2- - (-1,6) -2% "@D" -o44- -2% -6c...6 - (-19,-2) "@C" 2pn(...'f...)',4-- (0,1) "@E" -5isib8 (6,9) +2...'ibB(''')4 24h24 (-14,0) n(...'32...')- (-12,0) "@B" -2jo15

Fig 1 A	K	Fig 2	K	Fig 3 D	K	Fig 4	K	Fig 5 C	K	Fig 6 E	K	Fig 7	K	Fig 8	K	Fig 9	K	Fig 10 B	K
7.2.1.1	6	7.5.7.4	15	7.4.1.2	15	8.5.8.2	11	1.3.14.1	22	8.4.2.4	14	8.8.8.3	19	5.2.1.1	17	1.3.11.1	20	2.2.3.4	26
9.1.3.8	12	9.1.2.6	12	9.4.3.4	11	9.1.3.6	10	9.1.1.2	8	9.12.1.5	6	9.1.5.2	4	9.4.1.2	9	9.2.4.6	12		
9.2.3.6	12	9.1.3.2	4			9.1.4.6	10	9.9.4.4	11	9.8.1.1	7	9.1.5.1	2	9.4.5.2	5				
9.9.3.6	14							9.1.1.1	6										
	44		31		26		31		47		27		25		31		32		26

Pilot: Wojciech Kotulski

A/C: Extra NG SP-ING

Team: POL

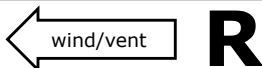

Figure K
320
Total K
350

Judges Name	
Signature	Number

Flight #

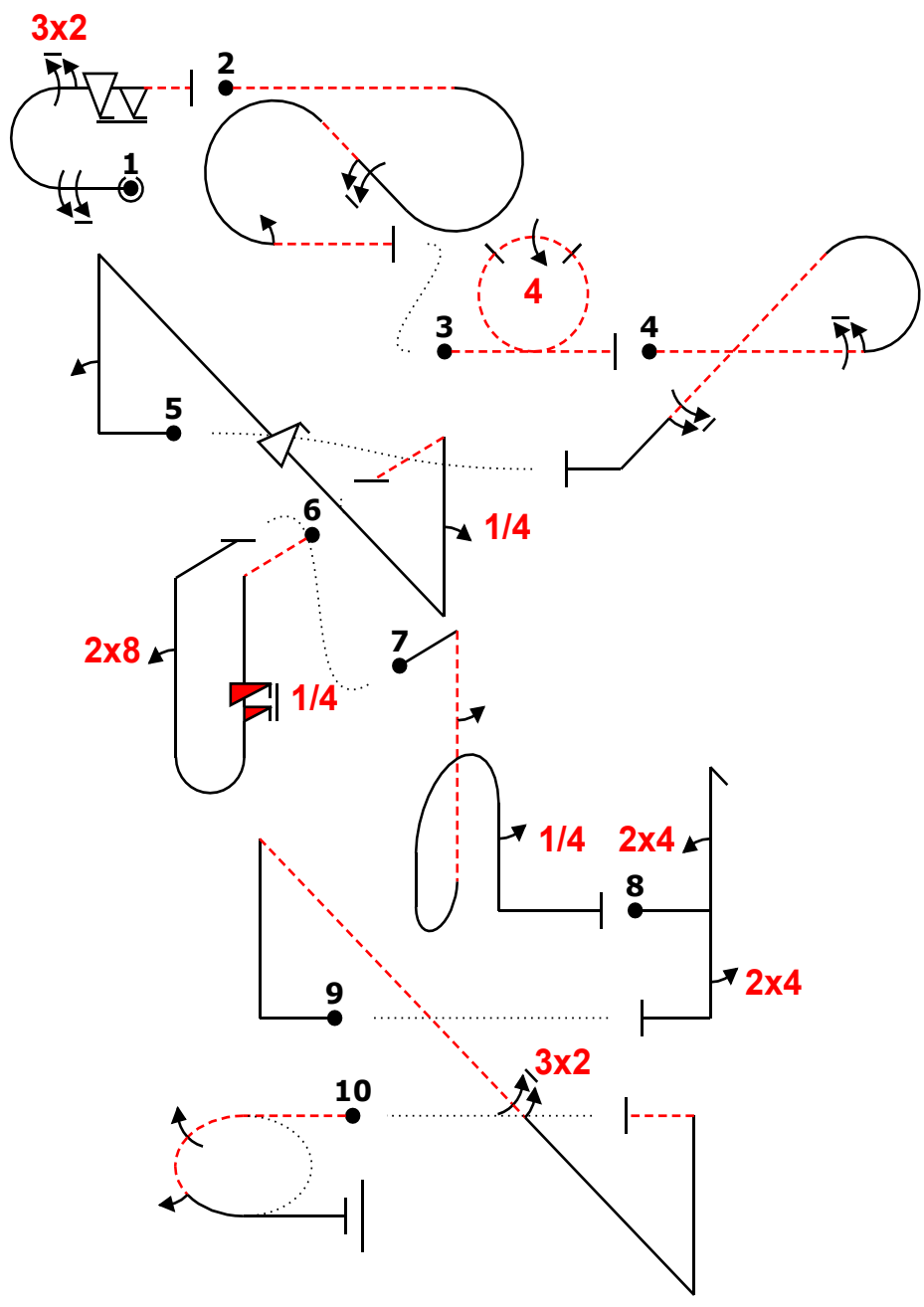

Fig	Grade	Pos	Remarks
1	.		
2	.		
3	.		
4	.		
5	.		
6	.		
7	.		
8	.		
9	.		
10	.		

Positioning
30

Too Low		Trg Violation	
Too High		Wing Rocks	
Interruptions		Disqual Fig	
Insertions		Other(note...)	

ed -3% "@A" 9m32,6f- -iic(6)2- -(-1,6) -2% "@D" -o44- -2% -6c...6" (-19,-2) "@C" 2pn(...'f...)',4-- (0,1) "@E" -5isib8 (6,9) +2...'ibB(''4 24h24 (-14,0) n(....'32....')- (-12,0) "@B" -2jo15

Fig 1 A	K	Fig 2	K	Fig 3 D	K	Fig 4	K	Fig 5 C	K	Fig 6 E	K	Fig 7	K	Fig 8	K	Fig 9	K	Fig 10 B	K
7.2.1.1	6	7.5.7.4	15	7.4.1.2	15	8.5.8.2	11	1.3.14.1	22	8.4.2.4	14	8.8.8.3	19	5.2.1.1	17	1.3.11.1	20	2.2.3.4	26
9.1.3.8	12	9.1.2.6	12	9.4.3.4	11	9.1.3.6	10	9.1.1.2	8	9.12.1.5	6	9.1.5.2	4	9.4.1.2	9	9.2.4.6	12		
9.2.3.6	12	9.1.3.2	4			9.1.4.6	10	9.9.4.4	11	9.8.1.1	7	9.1.5.1	2	9.4.5.2	5				
9.9.3.6	14							9.1.1.1	6										
	44		31		26		31		47		27		25		31		32		26



CIVA Advanced

Free Known

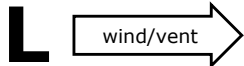

Figure K

320

Total K

350

Judges Name

Flight #

Signature

Number

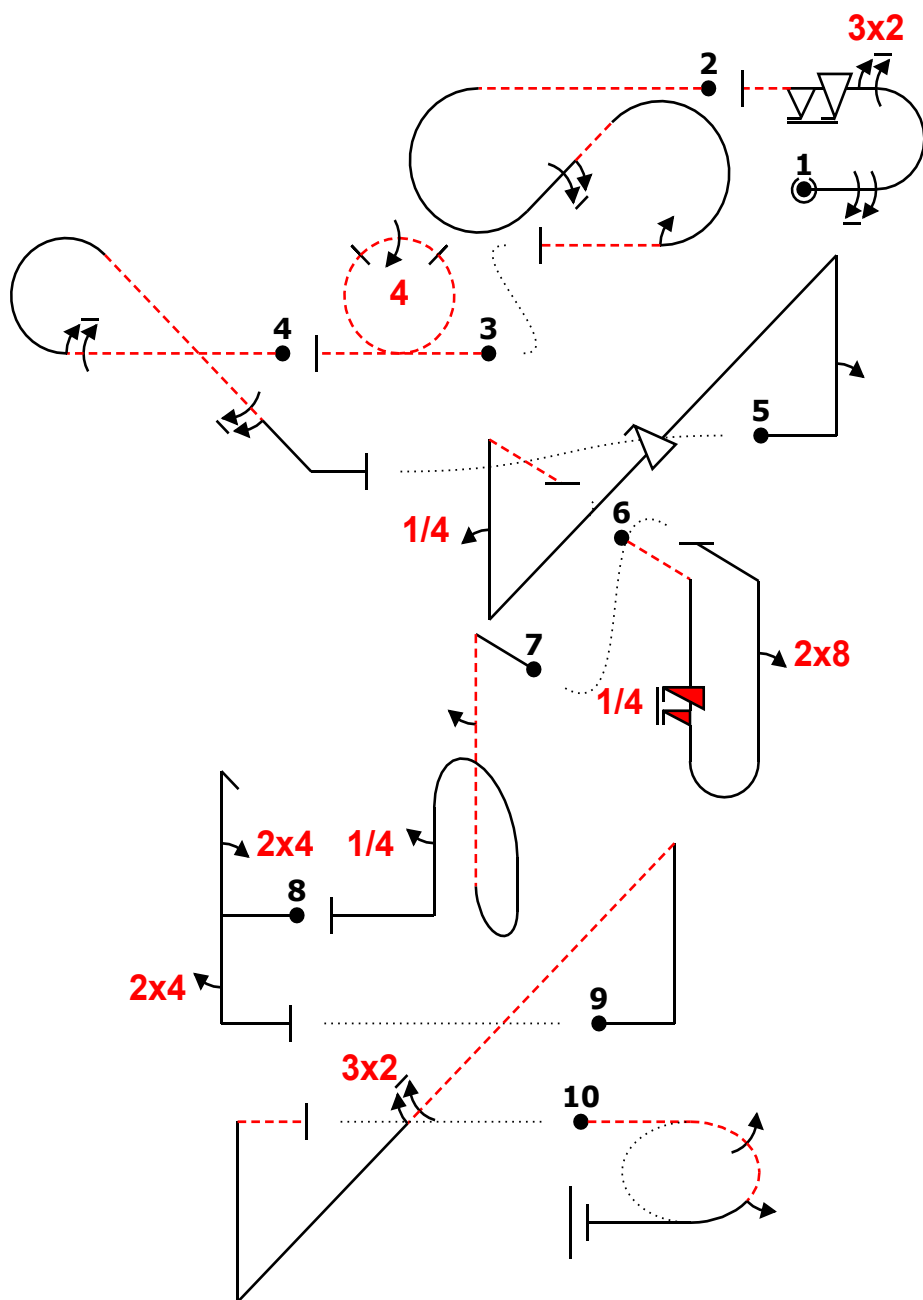

Fig	Grade	Pos	Remarks
1	.		
2	.		
3	.		
4	.		
5	.		
6	.		
7	.		
8	.		
9	.		
10	.		

Positioning

30

.

Too Low

Trg Violation

Too High

Wing Rocks

Interruptions

Disqual Fig

Insertions

Other(note...)

ed -3% "@A" 9m32,6f- -i ac(6)2- (-1,6) -2% "@D" -o44- -2% -6c...6 (-19,-2) "@C" 2pn(...'f...)',4-- (0,1) "@E" -5isib8 (6,9) +2...'ibB('')4 24h24 (-14,0) n(...'32...')- (-12,0) "@B" -2jo15

Fig 1 A	K	Fig 2	K	Fig 3 D	K	Fig 4	K	Fig 5 C	K	Fig 6 E	K	Fig 7	K	Fig 8	K	Fig 9	K	Fig 10 B	K
7.2.1.1	6	7.5.7.4	15	7.4.1.2	15	8.5.8.2	11	1.3.14.1	22	8.4.2.4	14	8.8.8.3	19	5.2.1.1	17	1.3.11.1	20	2.2.3.4	26
9.1.3.8	12	9.1.2.6	12	9.4.3.4	11	9.1.3.6	10	9.1.1.2	8	9.12.1.5	6	9.1.5.2	4	9.4.1.2	9	9.2.4.6	12		
9.2.3.6	12	9.1.3.2	4			9.1.4.6	10	9.9.4.4	11	9.8.1.1	7	9.1.5.1	2	9.4.5.2	5				
9.9.3.6	14							9.1.1.1	6										
	44		31		26		31		47		27		25		31		32		26

Pilot: Maciej Kulaszewski

A/C: Extra 330LX SP-KMD

Team: POL

wind/vent ← **R**

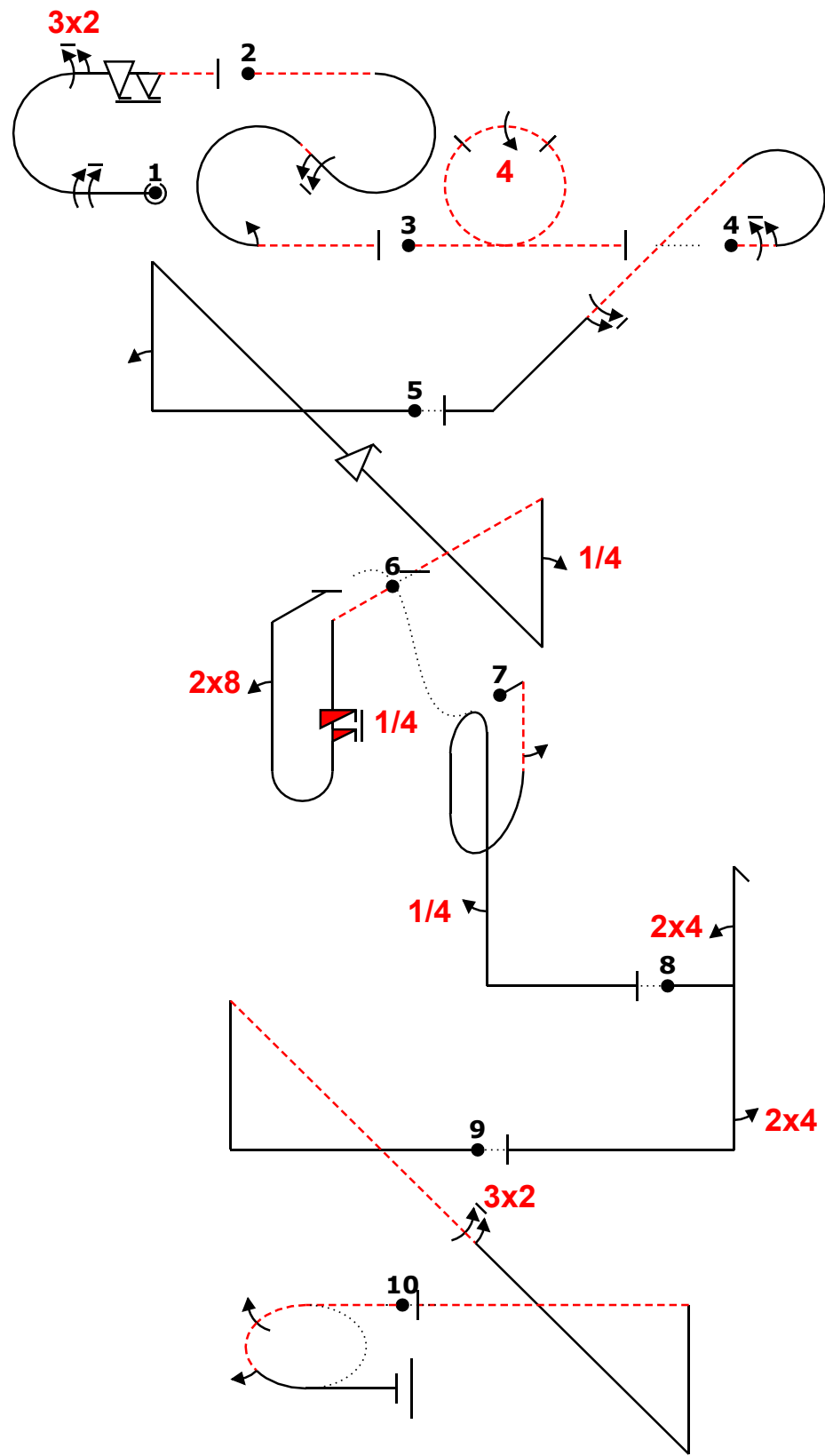

Fig	Grade	Pos	Remarks
1	.		
2	.		
3	.		
4	.		
5	.		
6	.		
7	.		
8	.		
9	.		
10	.		

Positioning
30 .

Too Low		Trg Violation	
Too High		Wing Rocks	
Interruptions		Disqual Fig	
Insertions		Other(note...)	

```
ed "@A" ,9m32,6f- -iac( "6" )2-..... "@D" -o44~ (3,0) -2%..... 6c..... '6' (2,0) "@C" ~+
++2pn(.....'f.....'),4~ (2,-1) "@E" -5isib8 (8,9) .....+2iBb(.....).....,4'+~ (-2,0) 24h..'24+++~ (2,0)
+++n(.....'32.....)..... (3,0) "@B" -2jo15
```

Fig 1 A	K	Fig 2	K	Fig 3 D	K	Fig 4	K	Fig 5 C	K	Fig 6 E	K	Fig 7	K	Fig 8	K	Fig 9	K	Fig 10 B	K
7.2.1.1	6	7.5.7.4	15	7.4.1.2	15	8.5.8.2	11	1.3.14.1	22	8.4.2.4	14	8.8.8.3	19	5.2.1.1	17	1.3.11.1	20	2.2.3.4	26
9.1.3.8	12	9.1.2.6	12	9.4.3.4	11	9.1.3.6	10	9.1.1.2	8	9.12.1.5	6	9.1.5.2	4	9.4.1.2	9	9.2.4.6	12		
9.2.3.6	12	9.1.3.2	4			9.1.4.6	10	9.9.4.4	11	9.8.1.1	7	9.1.5.1	2	9.4.5.2	5				
9.9.3.6	14							9.1.1.1	6										
	44		31		26		31		47		27		25		31		32		26



CIVA Advanced

Free Known

Figure K

320

Total K

350

Judges Name

Flight #

Signature

Number

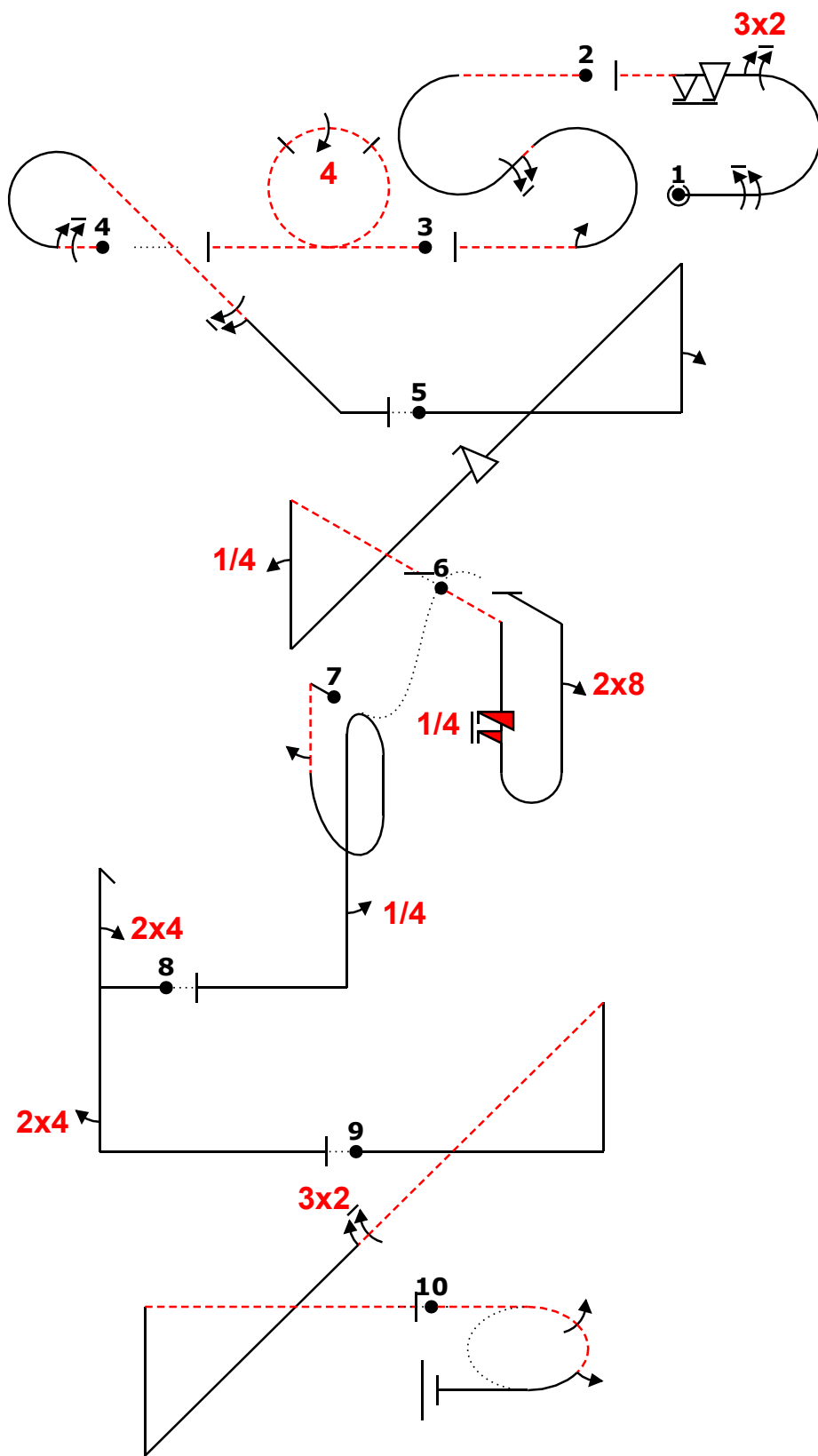
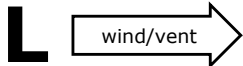

Fig	Grade	Pos	Remarks
1	.		
2	.		
3	.		
4	.		
5	.		
6	.		
7	.		
8	.		
9	.		
10	.		

Positioning

30

.

Too Low

Trg Violation

Too High

Wing Rocks

Interruptions

Disqual Fig

Insertions

Other(note...)

ed "@A" ,9m32,6f-...iac("6")2... " @D" -o44~ (3,0) -2%...6c... "6" (2,0) "@C" ~+
 ++2pn(...'f...'),4~ (2,-1) "@E" -5isib8 (8,9) ~~~~+2iBb(" ")... ,4'+~ (-2,0) 24h.' '24+++~ (2,0)
 +++n(...'32...')~ (3,0) "@B" -2jo15

Fig 1 A	K	Fig 2	K	Fig 3 D	K	Fig 4	K	Fig 5 C	K	Fig 6 E	K	Fig 7	K	Fig 8	K	Fig 9	K	Fig 10 B	K
7.2.1.1	6	7.5.7.4	15	7.4.1.2	15	8.5.8.2	11	1.3.14.1	22	8.4.2.4	14	8.8.8.3	19	5.2.1.1	17	1.3.11.1	20	2.2.3.4	26
9.1.3.8	12	9.1.2.6	12	9.4.3.4	11	9.1.3.6	10	9.1.1.2	8	9.12.1.5	6	9.1.5.2	4	9.4.1.2	9	9.2.4.6	12		
9.2.3.6	12	9.1.3.2	4			9.1.4.6	10	9.9.4.4	11	9.8.1.1	7	9.1.5.1	2	9.4.5.2	5				
9.9.3.6	14							9.1.1.1	6										
	44		31		26		31		47		27		25		31		32		26

Pilot: Dariusz Mazur

A/C: E330 LX SP-KMD

Team: POL

wind/vent ← **R**

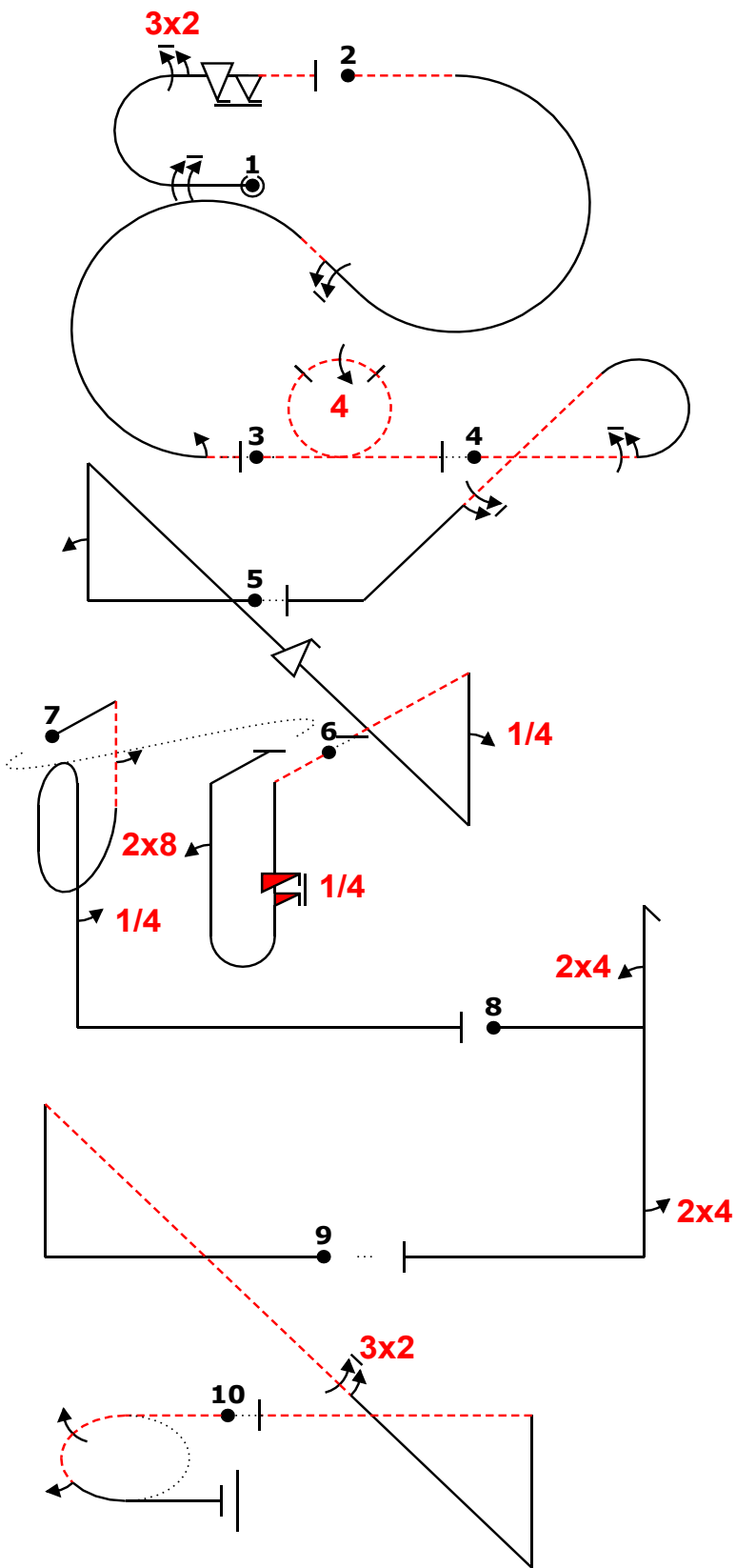

Fig	Grade	Pos	Remarks
1	.		
2	.		
3	.		
4	.		
5	.		
6	.		
7	.		
8	.		
9	.		
10	.		

Positioning
30

Too Low		Trg Violation	
Too High		Wing Rocks	
Interruptions		Disqual Fig	
Insertions		Other(note...)	

ed "@A" -1% ,9m32,6f- 11% -.....iac(`6`)2-.....(-3,0) "@D" -2% -o44~ (-2,0) -2% -`6c...
 '6'~ (2,0) "@C" ++2`pn(...'f...'),4~ (2,-1) "@E" ~5isib8 (-17,1) `2`ibb(...'...')...4.++++~ +24
 h...'24'++++ (-1,0) ~++++n(.....32.....)~ (2,0) "@B" -2jo15

Fig 1 A	K	Fig 2	K	Fig 3 D	K	Fig 4	K	Fig 5 C	K	Fig 6 E	K	Fig 7	K	Fig 8	K	Fig 9	K	Fig 10 B	K
7.2.1.1	6	7.5.7.4	15	7.4.1.2	15	8.5.8.2	11	1.3.14.1	22	8.4.2.4	14	8.8.8.3	19	5.2.1.1	17	1.3.11.1	20	2.2.3.4	26
9.1.3.8	12	9.1.2.6	12	9.4.3.4	11	9.1.3.6	10	9.1.1.2	8	9.12.1.5	6	9.1.5.2	4	9.4.1.2	9	9.2.4.6	12		
9.2.3.6	12	9.1.3.2	4			9.1.4.6	10	9.9.4.4	11	9.8.1.1	7	9.1.5.1	2	9.4.5.2	5				
9.9.3.6	14					9.1.1.1	6												
	44		31		26		31		47		27		25		31		32		26

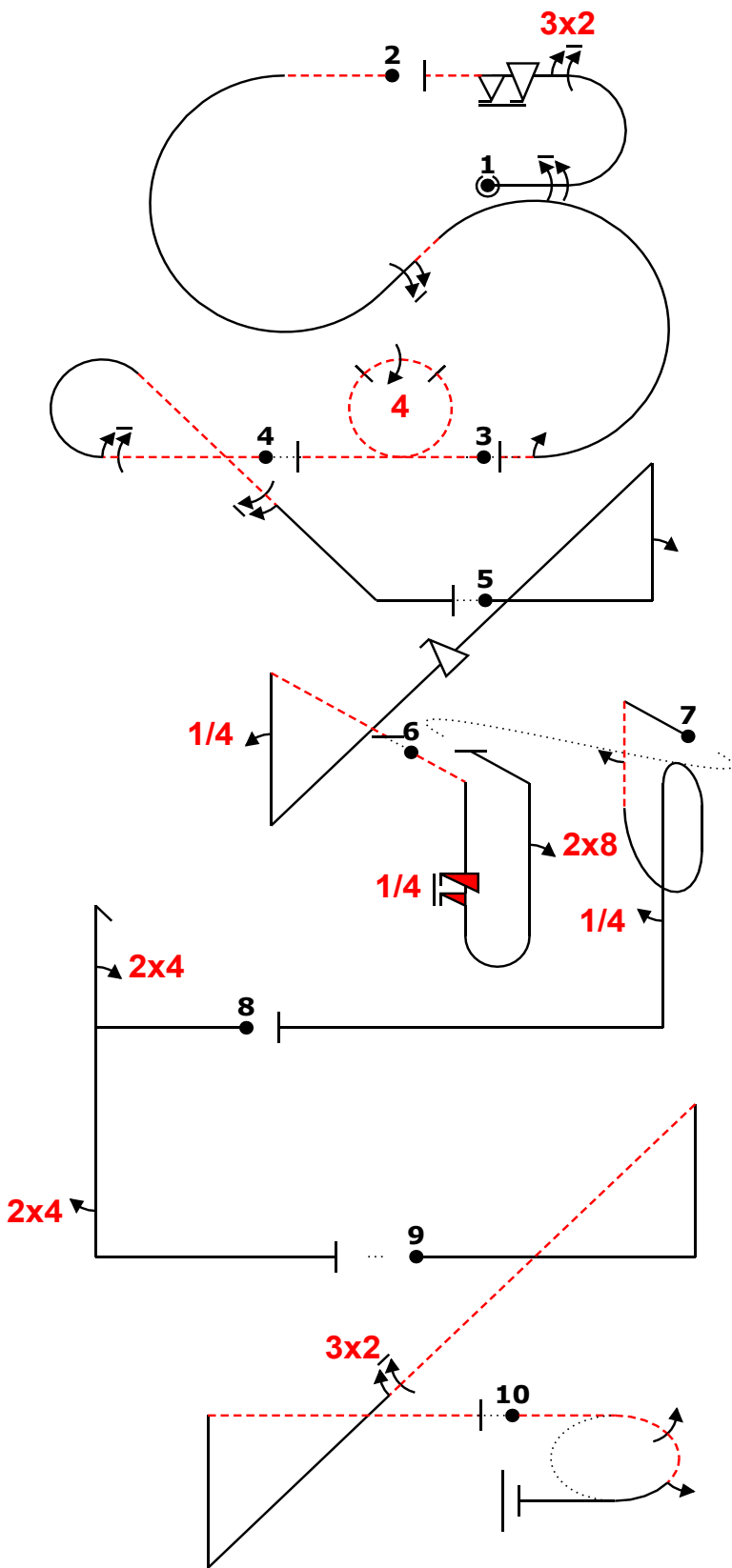
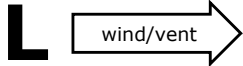

Fig	Grade	Pos	Remarks
1	.		
2	.		
3	.		
4	.		
5	.		
6	.		
7	.		
8	.		
9	.		
10	.		

Positioning	30	.
-------------	----	---

Too Low		Trg Violation	
Too High		Wing Rocks	
Interruptions		Disqual Fig	
Insertions		Other(note...)	

ed "@A" -1% ,9m32,6f- 11% -.....iac(`6`)2-..... (-3,0) "@D" -2% -o44~ (-2,0) -2% -`6c...
 '6'~ (2,0) "@C" ++2`pn(...'f...'),4~ (2,-1) "@E" ~5isib8 (-17,1) `2`ibb(...'...)'4.++++ ~+24
 h...'24'++++ (-1,0) ~++++n(.....32.....)~ (2,0) "@B" -2jo15

Fig 1 A	K	Fig 2	K	Fig 3 D	K	Fig 4	K	Fig 5 C	K	Fig 6 E	K	Fig 7	K	Fig 8	K	Fig 9	K	Fig 10 B	K
7.2.1.1	6	7.5.7.4	15	7.4.1.2	15	8.5.8.2	11	1.3.14.1	22	8.4.2.4	14	8.8.8.3	19	5.2.1.1	17	1.3.11.1	20	2.2.3.4	26
9.1.3.8	12	9.1.2.6	12	9.4.3.4	11	9.1.3.6	10	9.1.1.2	8	9.1.2.1.5	6	9.1.5.2	4	9.4.1.2	9	9.2.4.6	12		
9.2.3.6	12	9.1.3.2	4			9.1.4.6	10	9.9.4.4	11	9.8.1.1	7	9.1.5.1	2	9.4.5.2	5				
9.9.3.6	14					9.1.1.1	6												
	44		31		26		31		47		27		25		31		32		26

wind/vent ← **R**

Figure K
320
Total K
350

Judges Name
Signature
Number

Flight #

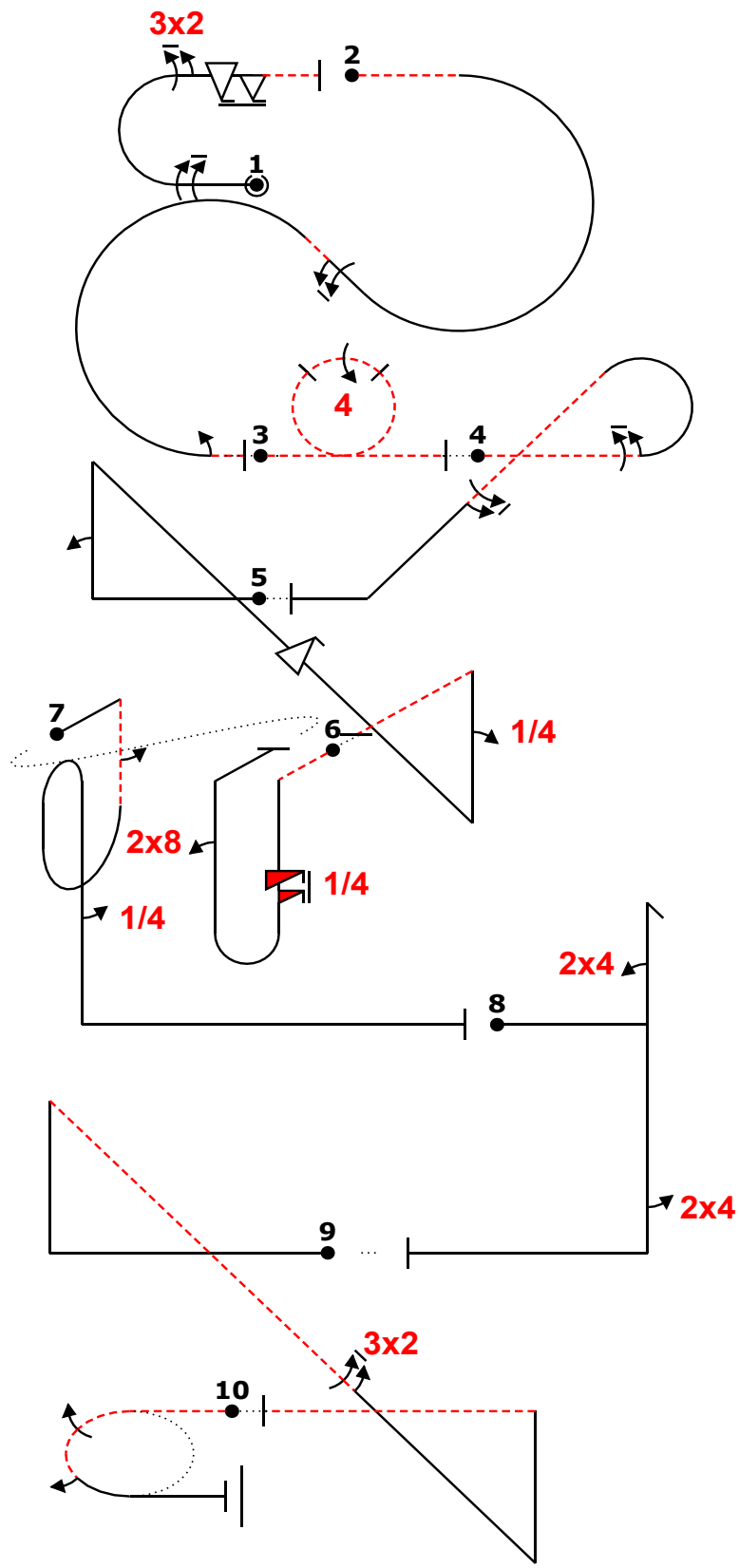

Fig	Grade	Pos	Remarks
1	.		
2	.		
3	.		
4	.		
5	.		
6	.		
7	.		
8	.		
9	.		
10	.		

Positioning
30

Too Low		Trg Violation	
Too High		Wing Rocks	
Interruptions		Disqual Fig	
Insertions		Other(note...)	

ed "@A" -1% ,9m32,6f- 11% -.....iac(`6`)2-.....(-3,0) "@D" -2% -o44~ (-2,0) -2% -`6c...
 '6'~ (2,0) "@C" ++2`pn(...f...'),4~ (2,-1) "@E" ~5isib8 (-17,1) `2`ibb(...')...4.++++ ~+24
 h...'24'++++ (-1,0) ~++++(...32....)~ (2,0) "@B" -2jo15

Fig 1 A	K	Fig 2	K	Fig 3 D	K	Fig 4	K	Fig 5 C	K	Fig 6 E	K	Fig 7	K	Fig 8	K	Fig 9	K	Fig 10 B	K
7.2.1.1	6	7.5.7.4	15	7.4.1.2	15	8.5.8.2	11	1.3.14.1	22	8.4.2.4	14	8.8.8.3	19	5.2.1.1	17	1.3.11.1	20	2.2.3.4	26
9.1.3.8	12	9.1.2.6	12	9.4.3.4	11	9.1.3.6	10	9.1.1.2	8	9.12.1.5	6	9.1.5.2	4	9.4.1.2	9	9.2.4.6	12		
9.2.3.6	12	9.1.3.2	4			9.1.4.6	10	9.9.4.4	11	9.8.1.1	7	9.1.5.1	2	9.4.5.2	5				
9.9.3.6	14					9.1.1.1	6												
	44		31		26		31		47		27		25		31		32		26

Judges Name	
Signature	Number

Flight #

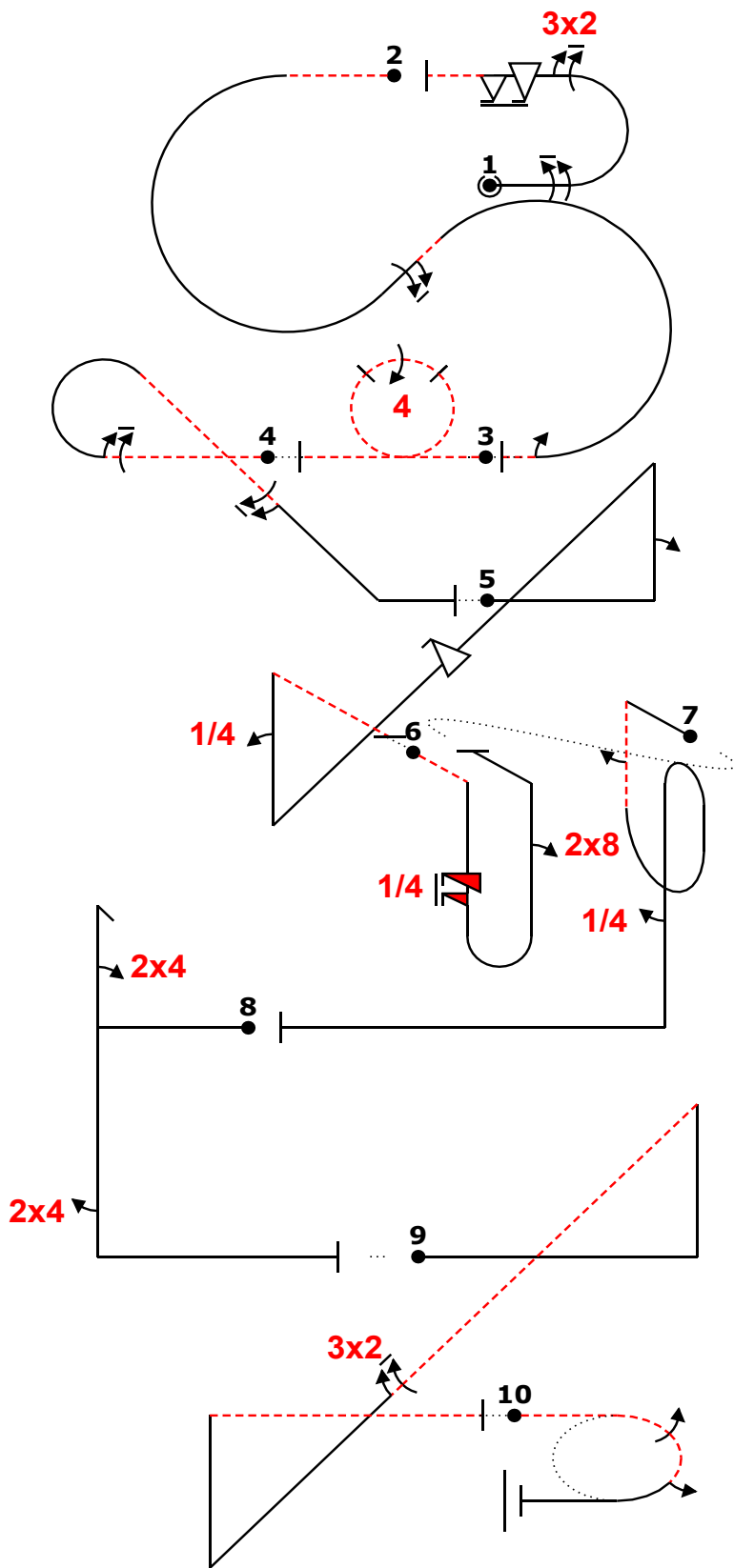
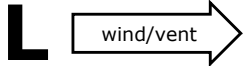

Fig	Grade	Pos	Remarks
1	.		
2	.		
3	.		
4	.		
5	.		
6	.		
7	.		
8	.		
9	.		
10	.		

Positioning	30	.
-------------	----	---

Too Low		Trg Violation	
Too High		Wing Rocks	
Interruptions		Disqual Fig	
Insertions		Other(note...)	

ed "@A" -1% ,9m32,6f- 11% -.....iac(`6`)2-.....(-3,0) "@D" -2% -o44~ (-2,0) -2% -`6c...
 '6'~ (2,0) "@C" ++2`pn(...'f...'),4~ (2,-1) "@E" ~5isib8 (-17,1) `2`ibb(.....)..'4.++++ ~+24
 h..'24'++++ (-1,0) +++++n(.....32.....)~ (2,0) "@B" -2jo15

Fig 1 A	K	Fig 2	K	Fig 3 D	K	Fig 4	K	Fig 5 C	K	Fig 6 E	K	Fig 7	K	Fig 8	K	Fig 9	K	Fig 10 B	K
7.2.1.1	6	7.5.7.4	15	7.4.1.2	15	8.5.8.2	11	1.3.14.1	22	8.4.2.4	14	8.8.8.3	19	5.2.1.1	17	1.3.11.1	20	2.2.3.4	26
9.1.3.8	12	9.1.2.6	12	9.4.3.4	11	9.1.3.6	10	9.1.1.2	8	9.12.1.5	6	9.1.5.2	4	9.4.1.2	9	9.2.4.6	12		
9.2.3.6	12	9.1.3.2	4			9.1.4.6	10	9.9.4.4	11	9.8.1.1	7	9.1.5.1	2	9.4.5.2	5				
9.9.3.6	14					9.1.1.1	6												
	44		31		26		31		47		27		25		31		32		26

wind/vent ← **R**

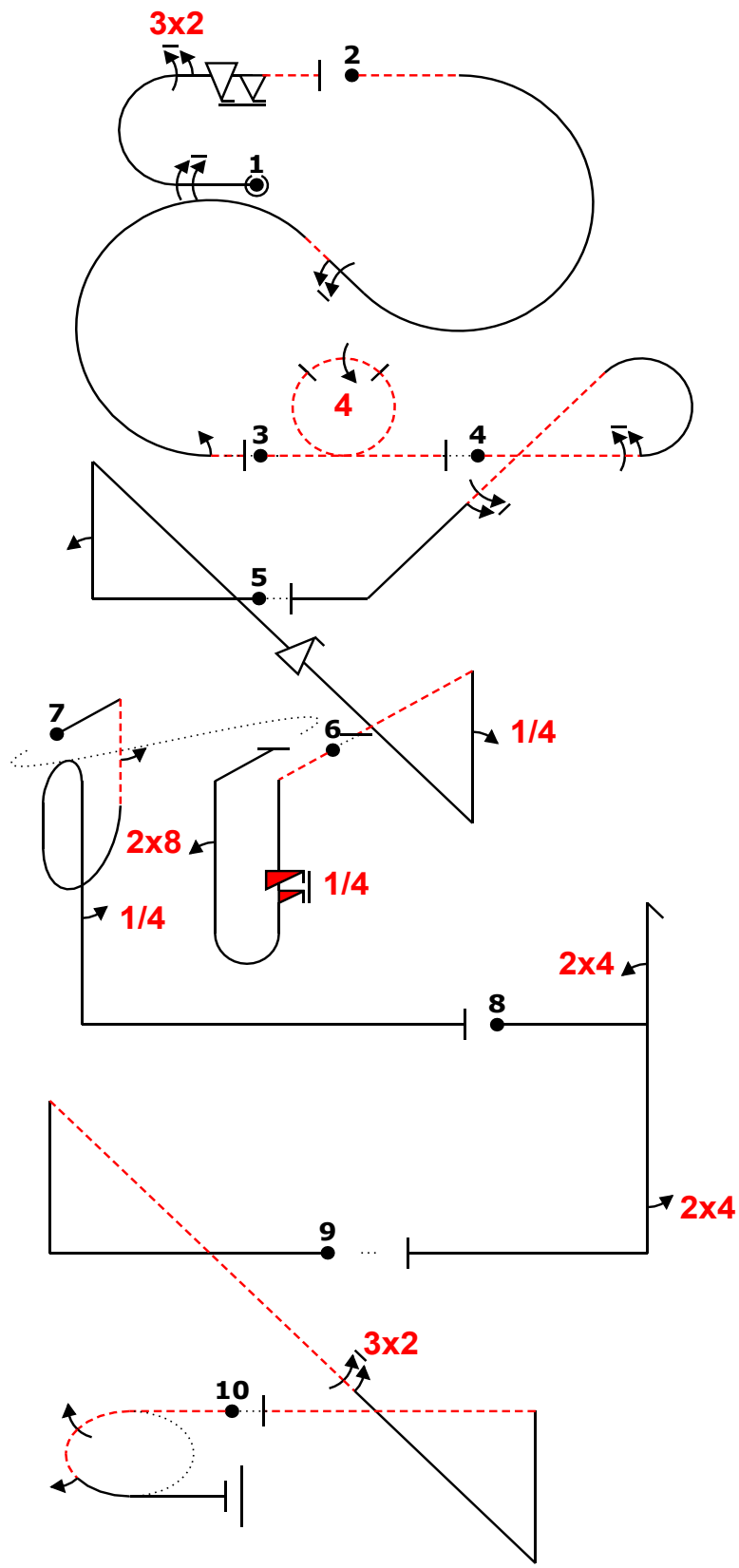

Fig	Grade	Pos	Remarks
1	.		
2	.		
3	.		
4	.		
5	.		
6	.		
7	.		
8	.		
9	.		
10	.		

Positioning
30 .

Too Low		Trg Violation	
Too High		Wing Rocks	
Interruptions		Disqual Fig	
Insertions		Other(note...)	

ed "@A" -1% ,9m32,6f- 11% -.....iac(`6`)2-.....(-3,0) "@D" -2% -o44~ (-2,0) -2% -`6c...
 '6'~ (2,0) "@C" ++2`pn(...'f...'),4~ (2,-1) "@E" ~5isib8 (-17,1) `2`ibb(...'...')...4.++++~ +24
 h...'24'++++ (-1,0) ~++++n(.....32.....)~ (2,0) "@B" -2jo15

Fig 1 A	K	Fig 2	K	Fig 3 D	K	Fig 4	K	Fig 5 C	K	Fig 6 E	K	Fig 7	K	Fig 8	K	Fig 9	K	Fig 10 B	K
7.2.1.1	6	7.5.7.4	15	7.4.1.2	15	8.5.8.2	11	1.3.14.1	22	8.4.2.4	14	8.8.8.3	19	5.2.1.1	17	1.3.11.1	20	2.2.3.4	26
9.1.3.8	12	9.1.2.6	12	9.4.3.4	11	9.1.3.6	10	9.1.1.2	8	9.12.1.5	6	9.1.5.2	4	9.4.1.2	9	9.2.4.6	12		
9.2.3.6	12	9.1.3.2	4			9.1.4.6	10	9.9.4.4	11	9.8.1.1	7	9.1.5.1	2	9.4.5.2	5				
9.9.3.6	14					9.1.1.1	6												
	44		31		26		31		47		27		25		31		32		26

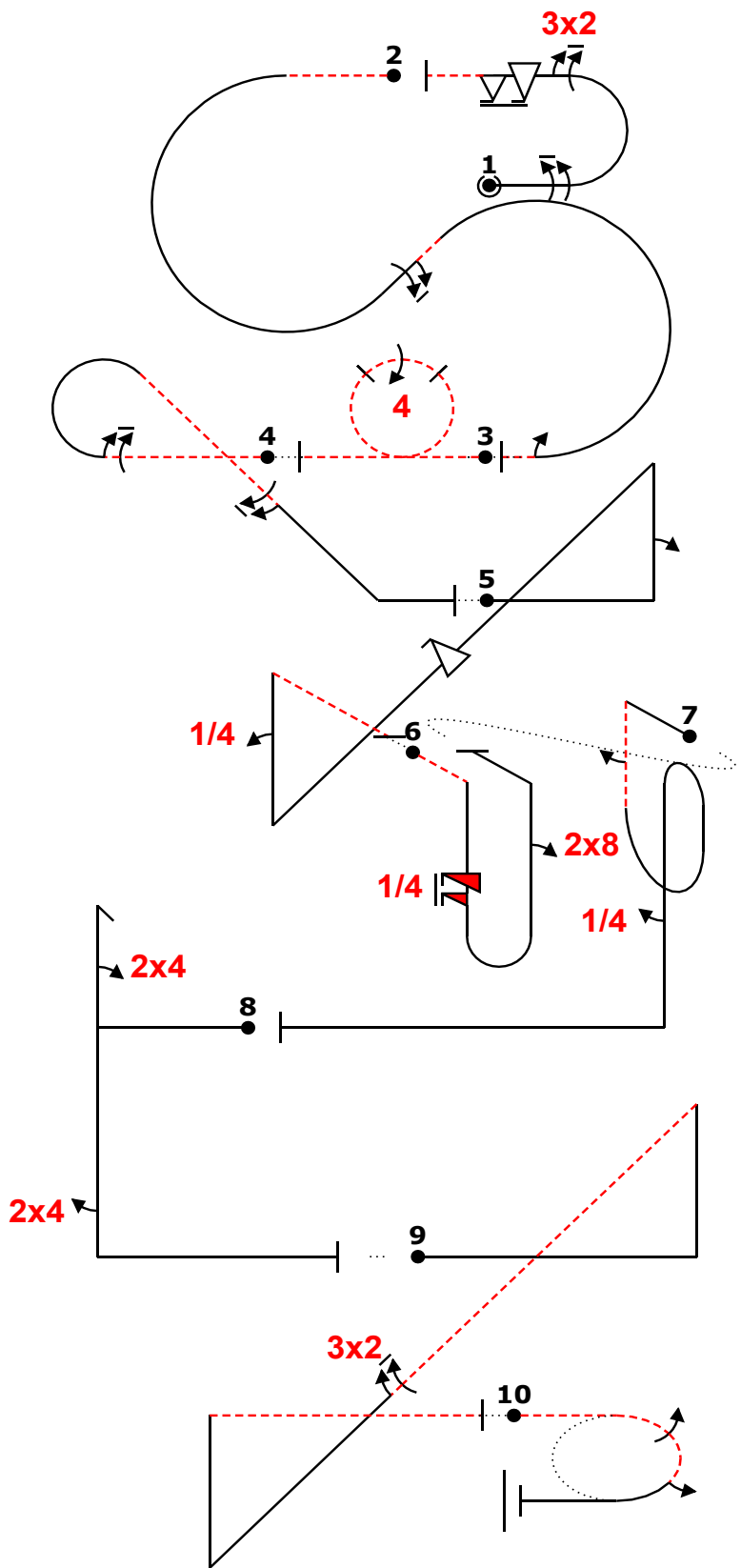
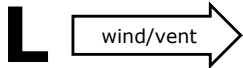

Fig	Grade	Pos	Remarks
1	.		
2	.		
3	.		
4	.		
5	.		
6	.		
7	.		
8	.		
9	.		
10	.		

Positioning	30	.
-------------	----	---

Too Low		Trg Violation	
Too High		Wing Rocks	
Interruptions		Disqual Fig	
Insertions		Other(note...)	

ed "@A" -1% ,9m32,6f- 11% -.....iac(`6`)2-..... (-3,0) "@D" -2% -o44~ (-2,0) -2% -`6c...
 '6'~ (2,0) "@C" ++2`pn(...'f...'),4~ (2,-1) "@E" ~5isib8 (-17,1) `2`ibb(...'4.++++ ~+24
 h...'24'++++ (-1,0) +++++(...32....)~ (2,0) "@B" -2jo15

Fig 1 A	K	Fig 2	K	Fig 3 D	K	Fig 4	K	Fig 5 C	K	Fig 6 E	K	Fig 7	K	Fig 8	K	Fig 9	K	Fig 10 B	K
7.2.1.1	6	7.5.7.4	15	7.4.1.2	15	8.5.8.2	11	1.3.14.1	22	8.4.2.4	14	8.8.8.3	19	5.2.1.1	17	1.3.11.1	20	2.2.3.4	26
9.1.3.8	12	9.1.2.6	12	9.4.3.4	11	9.1.3.6	10	9.1.1.2	8	9.12.1.5	6	9.1.5.2	4	9.4.1.2	9	9.2.4.6	12		
9.2.3.6	12	9.1.3.2	4			9.1.4.6	10	9.9.4.4	11	9.8.1.1	7	9.1.5.1	2	9.4.5.2	5				
9.9.3.6	14					9.1.1.1	6												
	44		31		26		31		47		27		25		31		32		26

wind/vent ← **R**

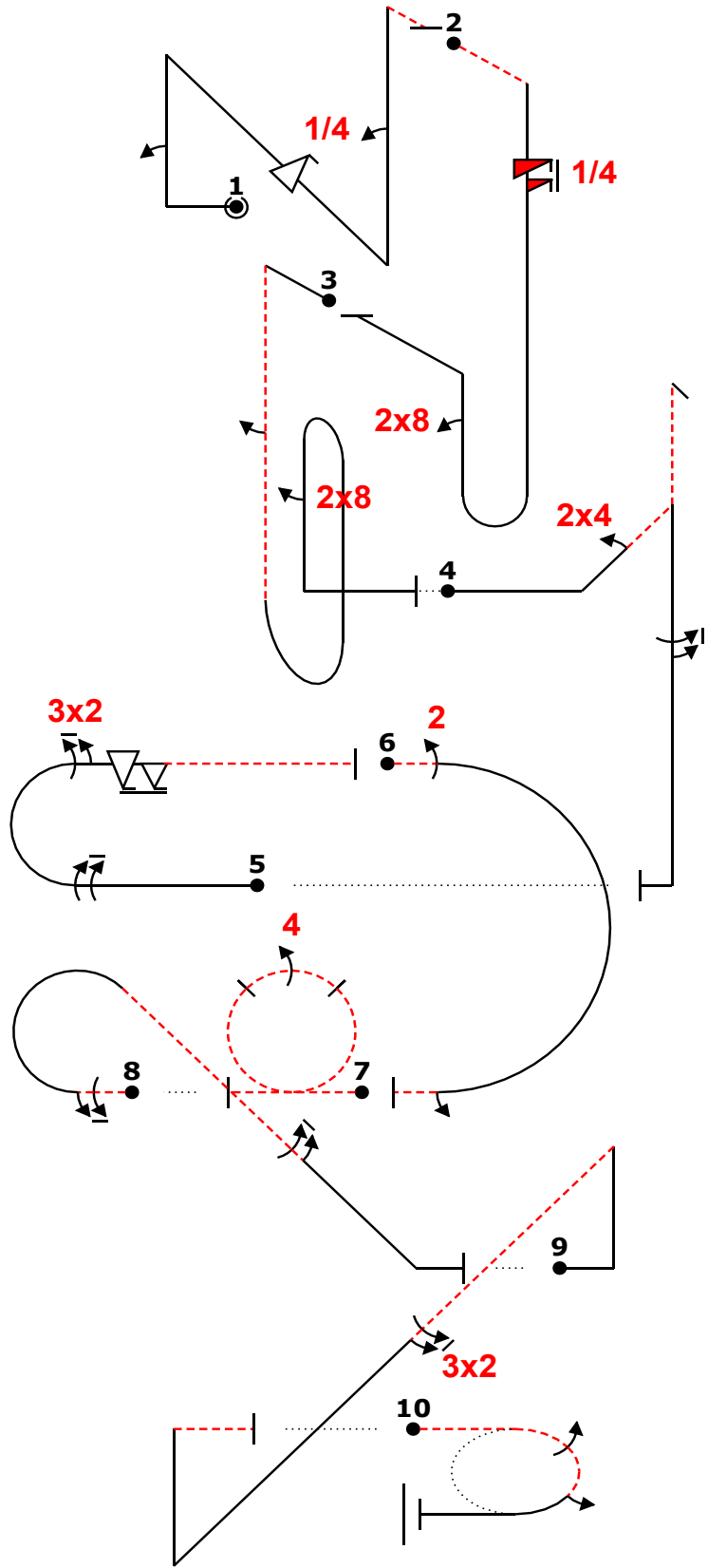

Fig	Grade	Pos	Remarks
1	.		
2	.		
3	.		
4	.		
5	.		
6	.		
7	.		
8	.		
9	.		
10	.		

Positioning
30 .

Too Low		Trg Violation	
Too High		Wing Rocks	
Interruptions		Disqual Fig	
Insertions		Other(note...)	

ed "@C" /2pn(.f.)-4.- "E" ~ 5is.....ib'8'+~...2...ibb(')'|'8'~ (-2,0) ~+24dh.'6....'+` (-20,0)
"@A" ...9m32,6f--- 17% -22a2-""@D" -o44- (-2,0) -6c....6'+ (2,0) '+`n(...32.....)'~
(6,0) "@B" -2jo15

Fig 1 C	K	Fig 2 E	K	Fig 3	K	Fig 4	K	Fig 5 A	K	Fig 6	K	Fig 7 D	K	Fig 8	K	Fig 9	K	Fig 10 B	K
1.3.14.1	22	8.4.2.4	14	8.8.8.3	19	5.3.2.1	24	7.2.1.1	6	7.2.2.4	7	7.4.1.2	15	8.5.8.2	11	1.3.11.1	20	2.2.3.4	26
9.1.1.2	8	9.12.1.5	6	9.1.5.2	4	9.4.2.2	7	9.1.3.8	12	9.2.3.4	9	9.4.3.4	11	9.1.3.6	10	9.2.4.6	12		
9.9.4.4	11	9.8.1.1	7	9.8.5.1	3	9.1.5.6	10	9.2.3.6	12	9.1.3.2	4			9.1.4.6	10				
9.1.1.1	6							9.9.3.6	14										
	47		27		26		41		44		20		26		31		32		26

Pilot: Teodor Munteanu

A/C: YR-EXC YR-EXC

Team: ROU

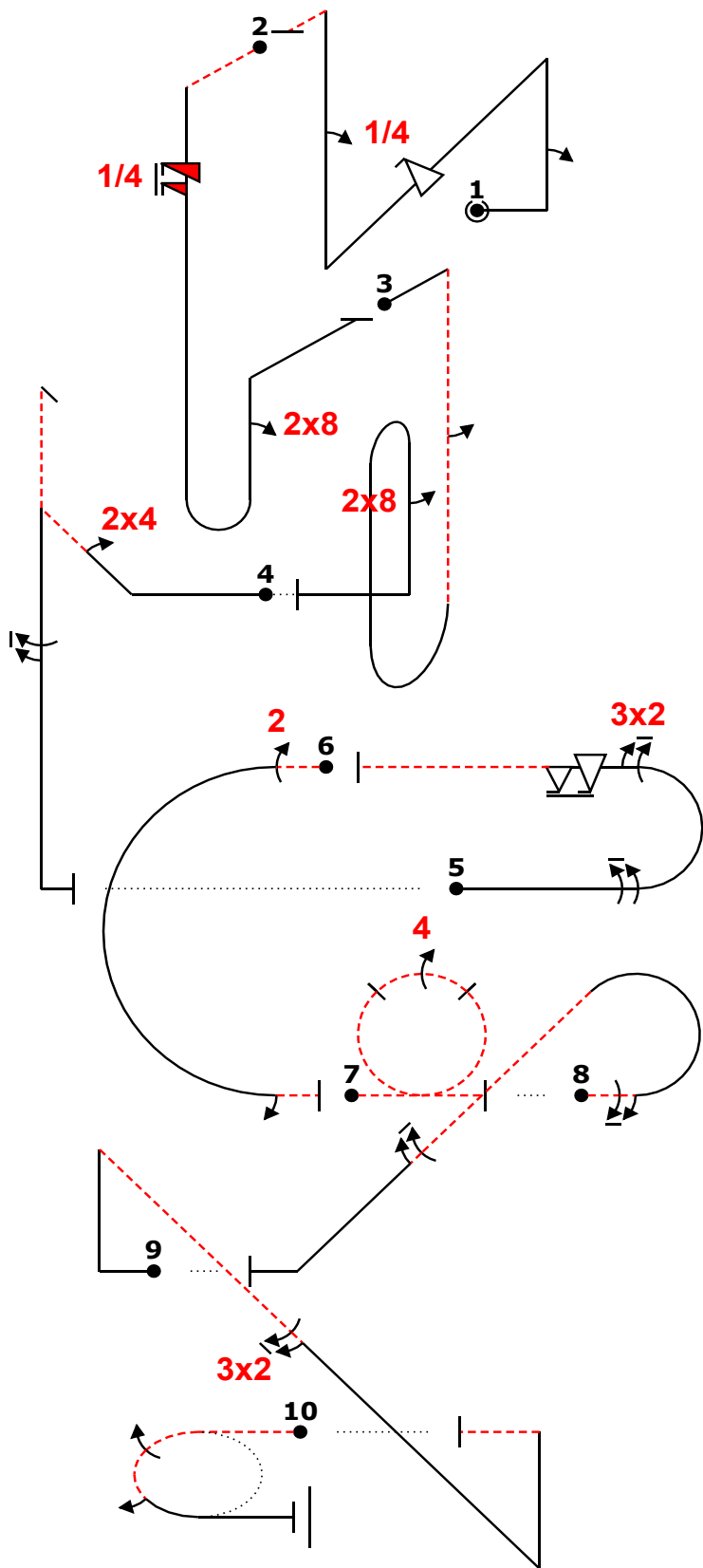
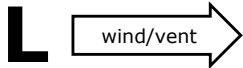

Fig	Grade	Pos	Remarks
1	.		
2	.		
3	.		
4	.		
5	.		
6	.		
7	.		
8	.		
9	.		
10	.		

Positioning
30 .

Too Low		Trg Violation	
Too High		Wing Rocks	
Interruptions		Disqual Fig	
Insertions		Other(note...)	

ed "@C" /2pn(.f.)-4.- "E" ~ 5is.....ib'8'+~w...2...ibb(")'"|"8'~ (-2,0) ~+24dh.'6....'+` (-20,0)
"@A" ...9m32,6f--- 17% -22a2- "D" -o44- (-2,0) -6c....6'+ (2,0) '+`n(...32.....)'~
(6,0) "@B" -2jo15

Fig 1 C	K	Fig 2 E	K	Fig 3	K	Fig 4	K	Fig 5 A	K	Fig 6	K	Fig 7 D	K	Fig 8	K	Fig 9	K	Fig 10 B	K
1.3.14.1	22	8.4.2.4	14	8.8.8.3	19	5.3.2.1	24	7.2.1.1	6	7.2.2.4	7	7.4.1.2	15	8.5.8.2	11	1.3.11.1	20	2.2.3.4	26
9.1.1.2	8	9.12.1.5	6	9.1.5.2	4	9.4.2.2	7	9.1.3.8	12	9.2.3.4	9	9.4.3.4	11	9.1.3.6	10	9.2.4.6	12		
9.9.4.4	11	9.8.1.1	7	9.8.5.1	3	9.1.5.6	10	9.2.3.6	12	9.1.3.2	4			9.1.4.6	10				
9.1.1.1	6							9.9.3.6	14										
	47		27		26		41		44		20		26		31		32		26

Pilot: Teodor Munteanu

A/C: YR-EXC YR-EXC

Team: ROU

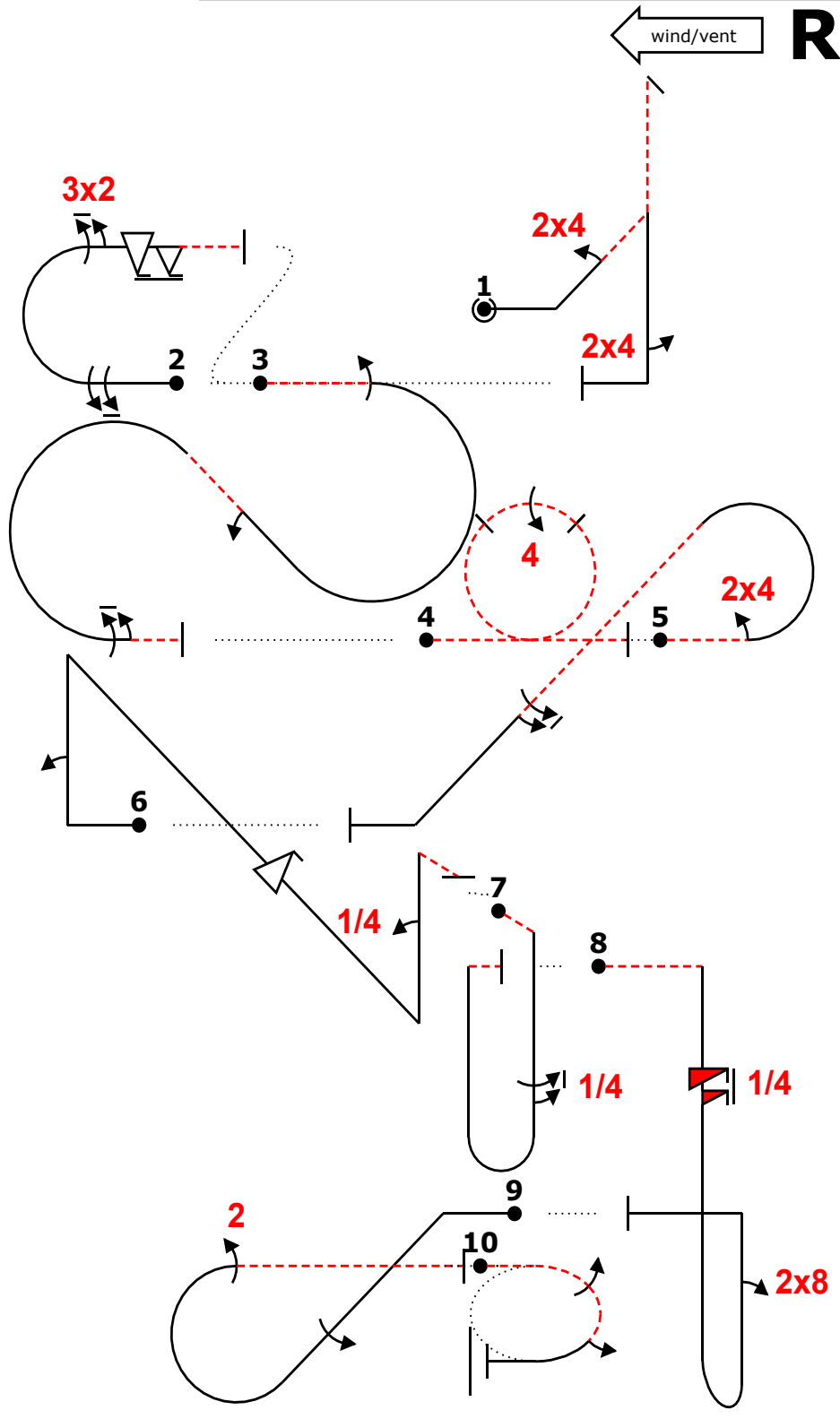

Fig	Grade	Pos	Remarks
1	.		
2	.		
3	.		
4	.		
5	.		
6	.		
7	.		
8	.		
9	.		
10	.		

Positioning
30 .

Too Low		Trg Violation	
Too High		Wing Rocks	
Interruptions		Disqual Fig	
Insertions		Other(note...)	

24dh."| "24 (-21,0) "@A" 9m32,6f- (-3,8) 6% ~~~~~ i1ac(2)6- (11,0) "@D" -o44- (-2,0) ~~~~~
 ~~~~~ 24c....6 (-9,0) "@C" /2pn(...'f...')4- (-1,0) ~~~~~ .5ib~>> (2,0) "@E" -5is....'ib,8~ (-3,0) i1rc22- (-3,0)  
 "@B" ~~~~~-2jo15+~

| Fig 1   | K         | Fig 2 A | K         | Fig 3   | K         | Fig 4 D | K         | Fig 5   | K         | Fig 6 C  | K         | Fig 7   | K         | Fig 8 E  | K         | Fig 9   | K         | Fig 10 B | K         |
|---------|-----------|---------|-----------|---------|-----------|---------|-----------|---------|-----------|----------|-----------|---------|-----------|----------|-----------|---------|-----------|----------|-----------|
| 5.3.2.1 | 24        | 7.2.1.1 | 6         | 7.5.7.4 | 15        | 7.4.1.2 | 15        | 8.5.8.2 | 11        | 1.3.14.1 | 22        | 8.4.1.4 | 13        | 8.4.2.4  | 14        | 8.5.1.3 | 10        | 2.2.3.4  | 26        |
| 9.4.2.2 | 7         | 9.1.3.8 | 12        | 9.1.3.4 | 8         | 9.4.3.4 | 11        | 9.4.3.2 | 5         | 9.1.1.2  | 8         | 9.1.5.5 | 9         | 9.12.1.5 | 6         | 9.1.4.4 | 8         |          |           |
| 9.4.5.2 | 5         | 9.2.3.6 | 12        | 9.1.2.2 | 6         |         |           | 9.1.4.6 | 10        | 9.9.4.4  | 11        |         |           | 9.8.1.1  | 7         | 9.2.3.4 | 9         |          |           |
|         |           | 9.9.3.6 | 14        | 9.1.3.6 | 10        |         |           |         |           | 9.1.1.1  | 6         |         |           |          |           |         |           |          |           |
|         | <b>36</b> |         | <b>44</b> |         | <b>39</b> |         | <b>26</b> |         | <b>26</b> |          | <b>47</b> |         | <b>22</b> |          | <b>27</b> |         | <b>27</b> |          | <b>26</b> |



CIVA Advanced  
Free Known

Figure K  
320  
Total K  
350

Judges Name  
Signature  
Number

Flight #

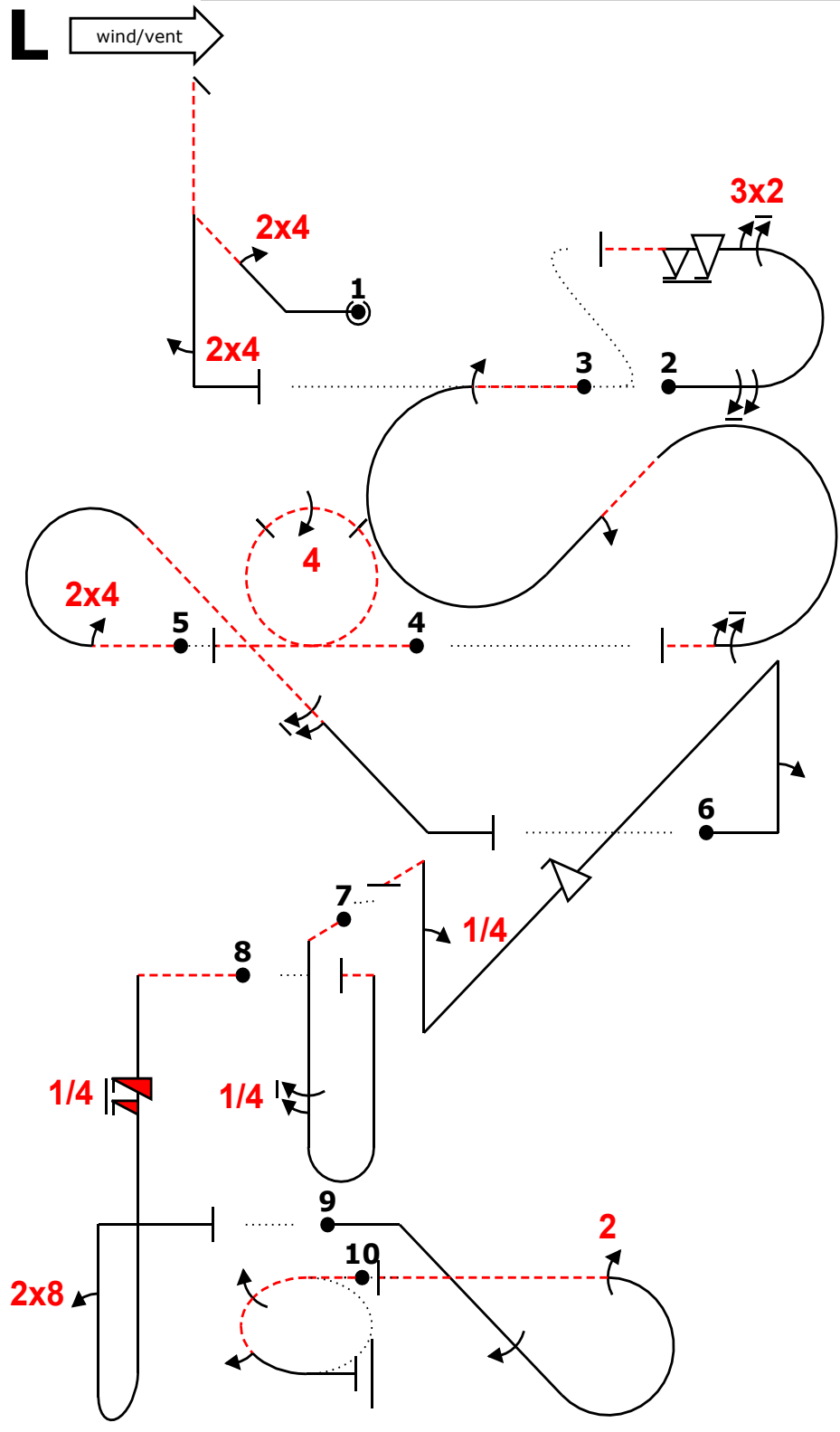

| Fig | Grade | Pos | Remarks |
|-----|-------|-----|---------|
| 1   | .     |     |         |
| 2   | .     |     |         |
| 3   | .     |     |         |
| 4   | .     |     |         |
| 5   | .     |     |         |
| 6   | .     |     |         |
| 7   | .     |     |         |
| 8   | .     |     |         |
| 9   | .     |     |         |
| 10  | .     |     |         |

Positioning  
30 .

|               |  |                |  |
|---------------|--|----------------|--|
| Too Low       |  | Trg Violation  |  |
| Too High      |  | Wing Rocks     |  |
| Interruptions |  | Disqual Fig    |  |
| Insertions    |  | Other(note...) |  |

24dh."| "24 (-21,0) "@A" 9m32,6f- (-3,8) 6% ..... i1ac(2)6-..... (11,0) "@D" -o44- (-2,0) -.....  
 ~~~~24c....6 (-9,0) "@C" /2pn(...'f...')4- (-1,0) ~~~~.5ib~>> (2,0) "@E" -5is.....'ib,8~ (-3,0) i1rc22- (-3,0)  
 "@B" ~~~~2jo15+~

| Fig 1 | K | Fig 2 A | K | Fig 3 | K | Fig 4 D | K | Fig 5 | K | Fig 6 C | K | Fig 7 | K | Fig 8 E | K | Fig 9 | K | Fig 10 B | K |
|---------|----|---------|----|---------|----|---------|----|---------|----|----------|----|---------|----|-----------|----|---------|----|----------|----|
| 5.3.2.1 | 24 | 7.2.1.1 | 6 | 7.5.7.4 | 15 | 7.4.1.2 | 15 | 8.5.8.2 | 11 | 1.3.14.1 | 22 | 8.4.1.4 | 13 | 8.4.2.4 | 14 | 8.5.1.3 | 10 | 2.2.3.4 | 26 |
| 9.4.2.2 | 7 | 9.1.3.8 | 12 | 9.1.3.4 | 8 | 9.4.3.4 | 11 | 9.4.3.2 | 5 | 9.1.1.2 | 8 | 9.1.5.5 | 9 | 9.1.2.1.5 | 6 | 9.1.4.4 | 8 | | |
| 9.4.5.2 | 5 | 9.2.3.6 | 12 | 9.1.2.2 | 6 | | | 9.1.4.6 | 10 | 9.9.4.4 | 11 | | | 9.8.1.1 | 7 | 9.2.3.4 | 9 | | |
| | 36 | 9.9.3.6 | 14 | 9.1.3.6 | 10 | | 26 | | 26 | 9.1.1.1 | 6 | | 22 | | 27 | | 27 | | 26 |
| | | | 44 | | 39 | | | | | | 47 | | | | | | | | |

Pilot: LUCIAN PINTEA

A/C: E300 YR-EXT

Team: ROU

wind/vent ←

R

Figure K

320

Total K

350

| | |
|-------------|--------|
| Judges Name | |
| Signature | Number |

Flight #

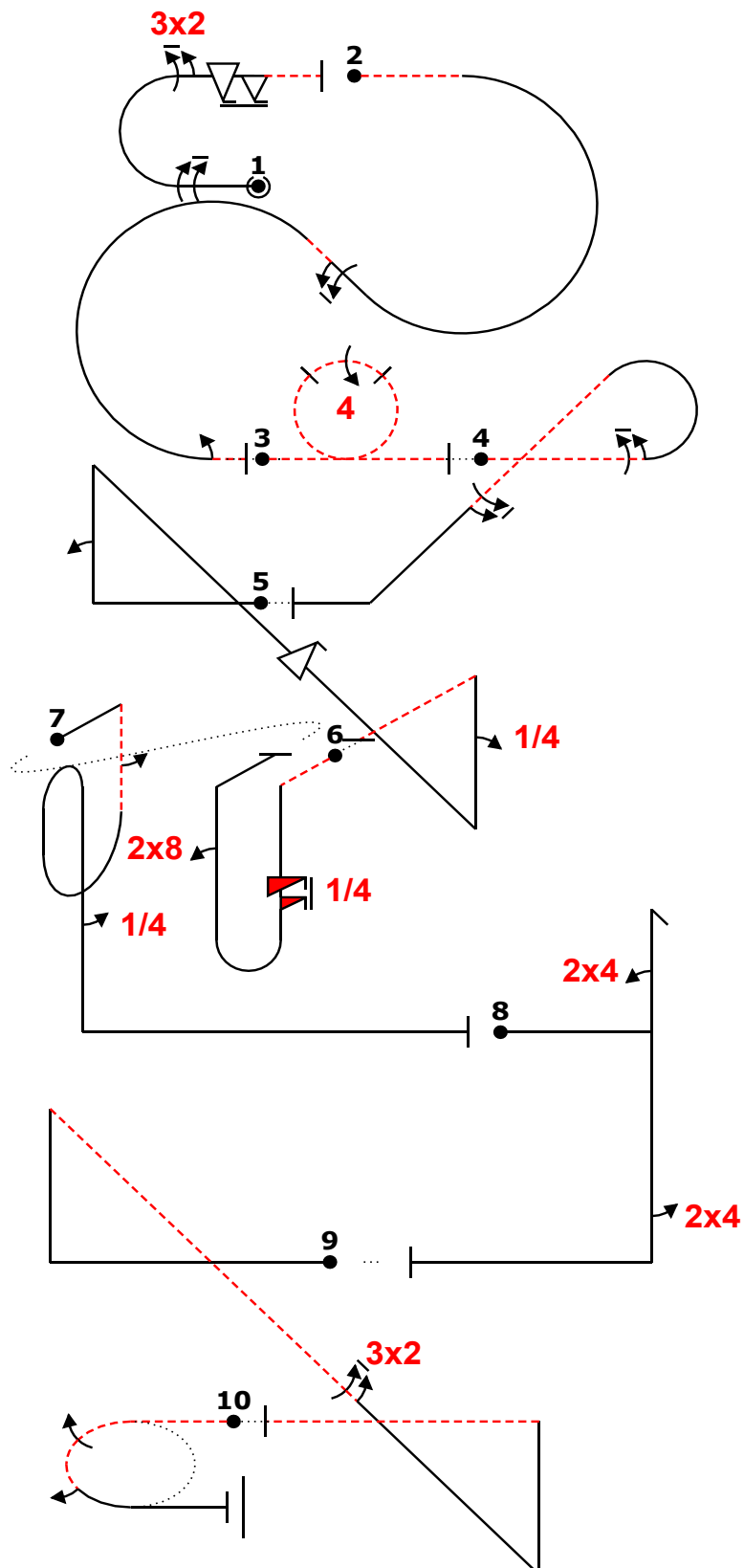

| Fig | Grade | Pos | Remarks |
|-----|-------|-----|---------|
| 1 | . | | |
| 2 | . | | |
| 3 | . | | |
| 4 | . | | |
| 5 | . | | |
| 6 | . | | |
| 7 | . | | |
| 8 | . | | |
| 9 | . | | |
| 10 | . | | |

Positioning 30 .

| | | | |
|---------------|--|----------------|--|
| Too Low | | Trg Violation | |
| Too High | | Wing Rocks | |
| Interruptions | | Disqual Fig | |
| Insertions | | Other(note...) | |

ed "@A" -1% ,9m32,6f- 11% -.....iac(`6`)2-.....(-3,0) "@D" -2% -o44~ (-2,0) -2% -`6c...
 '6'~ (2,0) "@C" ++2`pn(...f...'),4~ (2,-1) "@E" ~5isib8 (-17,1) `2`ibb(...')...4.++++ ~+24
 h...'24'++++ (-1,0) ~++++(...32....)~ (2,0) "@B" -2jo15

| Fig 1 A | K | Fig 2 | K | Fig 3 D | K | Fig 4 | K | Fig 5 C | K | Fig 6 E | K | Fig 7 | K | Fig 8 | K | Fig 9 | K | Fig 10 B | K |
|---------|-----------|---------|-----------|---------|-----------|---------|-----------|----------|-----------|----------|-----------|---------|-----------|---------|-----------|----------|-----------|----------|-----------|
| 7.2.1.1 | 6 | 7.5.7.4 | 15 | 7.4.1.2 | 15 | 8.5.8.2 | 11 | 1.3.14.1 | 22 | 8.4.2.4 | 14 | 8.8.8.3 | 19 | 5.2.1.1 | 17 | 1.3.11.1 | 20 | 2.2.3.4 | 26 |
| 9.1.3.8 | 12 | 9.1.2.6 | 12 | 9.4.3.4 | 11 | 9.1.3.6 | 10 | 9.1.1.2 | 8 | 9.12.1.5 | 6 | 9.1.5.2 | 4 | 9.4.1.2 | 9 | 9.2.4.6 | 12 | | |
| 9.2.3.6 | 12 | 9.1.3.2 | 4 | | | 9.1.4.6 | 10 | 9.9.4.4 | 11 | 9.8.1.1 | 7 | 9.1.5.1 | 2 | 9.4.5.2 | 5 | | | | |
| 9.9.3.6 | 14 | | | | | 9.1.1.1 | 6 | | | | | | | | | | | | |
| | 44 | | 31 | | 26 | | 31 | | 47 | | 27 | | 25 | | 31 | | 32 | | 26 |

Pilot: George Rotaru

A/C: EA330SC YR-EXB

Team: ROU

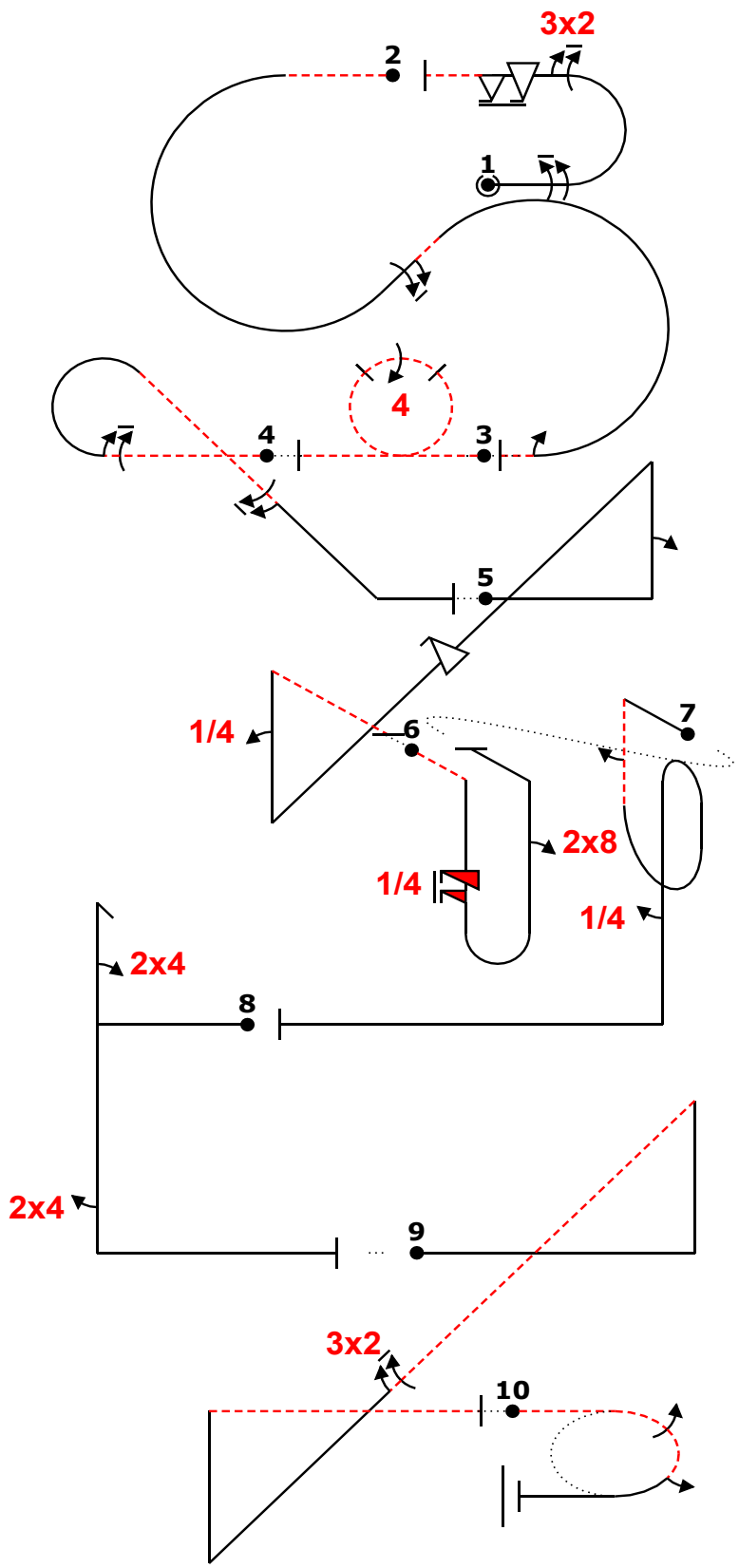
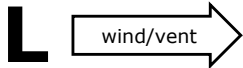

| Fig | Grade | Pos | Remarks |
|-----|-------|-----|---------|
| 1 | . | | |
| 2 | . | | |
| 3 | . | | |
| 4 | . | | |
| 5 | . | | |
| 6 | . | | |
| 7 | . | | |
| 8 | . | | |
| 9 | . | | |
| 10 | . | | |

Positioning
30

| |
|---|
| . |
|---|

| | | | |
|---------------|--|----------------|--|
| Too Low | | Trg Violation | |
| Too High | | Wing Rocks | |
| Interruptions | | Disqual Fig | |
| Insertions | | Other(note...) | |

ed "@A" -1% ,9m32,6f- 11% -.....iac(`6`)2-.....(-3,0) "@D" -2% -o44~ (-2,0) -2% -`6c...
 '6'~ (2,0) "@C" ++2`pn(...'f...'),4~ (2,-1) "@E" ~5isib8 (-17,1) `2`ibb(...'4.++++ ~+24
 h...'24'++++ (-1,0) +++++n(.....32.....)~ (2,0) "@B" -2jo15

| Fig 1 A | K | Fig 2 | K | Fig 3 D | K | Fig 4 | K | Fig 5 C | K | Fig 6 E | K | Fig 7 | K | Fig 8 | K | Fig 9 | K | Fig 10 B | K |
|---------|----|---------|----|---------|----|---------|----|----------|----|----------|----|---------|----|---------|----|----------|----|----------|----|
| 7.2.1.1 | 6 | 7.5.7.4 | 15 | 7.4.1.2 | 15 | 8.5.8.2 | 11 | 1.3.14.1 | 22 | 8.4.2.4 | 14 | 8.8.8.3 | 19 | 5.2.1.1 | 17 | 1.3.11.1 | 20 | 2.2.3.4 | 26 |
| 9.1.3.8 | 12 | 9.1.2.6 | 12 | 9.4.3.4 | 11 | 9.1.3.6 | 10 | 9.1.1.2 | 8 | 9.12.1.5 | 6 | 9.1.5.2 | 4 | 9.4.1.2 | 9 | 9.2.4.6 | 12 | | |
| 9.2.3.6 | 12 | 9.1.3.2 | 4 | | | 9.1.4.6 | 10 | 9.9.4.4 | 11 | 9.8.1.1 | 7 | 9.1.5.1 | 2 | 9.4.5.2 | 5 | | | | |
| 9.9.3.6 | 14 | | | | | 9.1.1.1 | 6 | | | | | | | | | | | | |
| | 44 | | 31 | | 26 | | 31 | | 47 | | 27 | | 25 | | 31 | | 32 | | 26 |



CIVA Advanced

Free Known

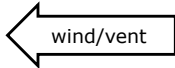

R

Figure K

320

Total K

350

| | | |
|-------------|--------|----------|
| Judges Name | | Flight # |
| Signature | Number | |

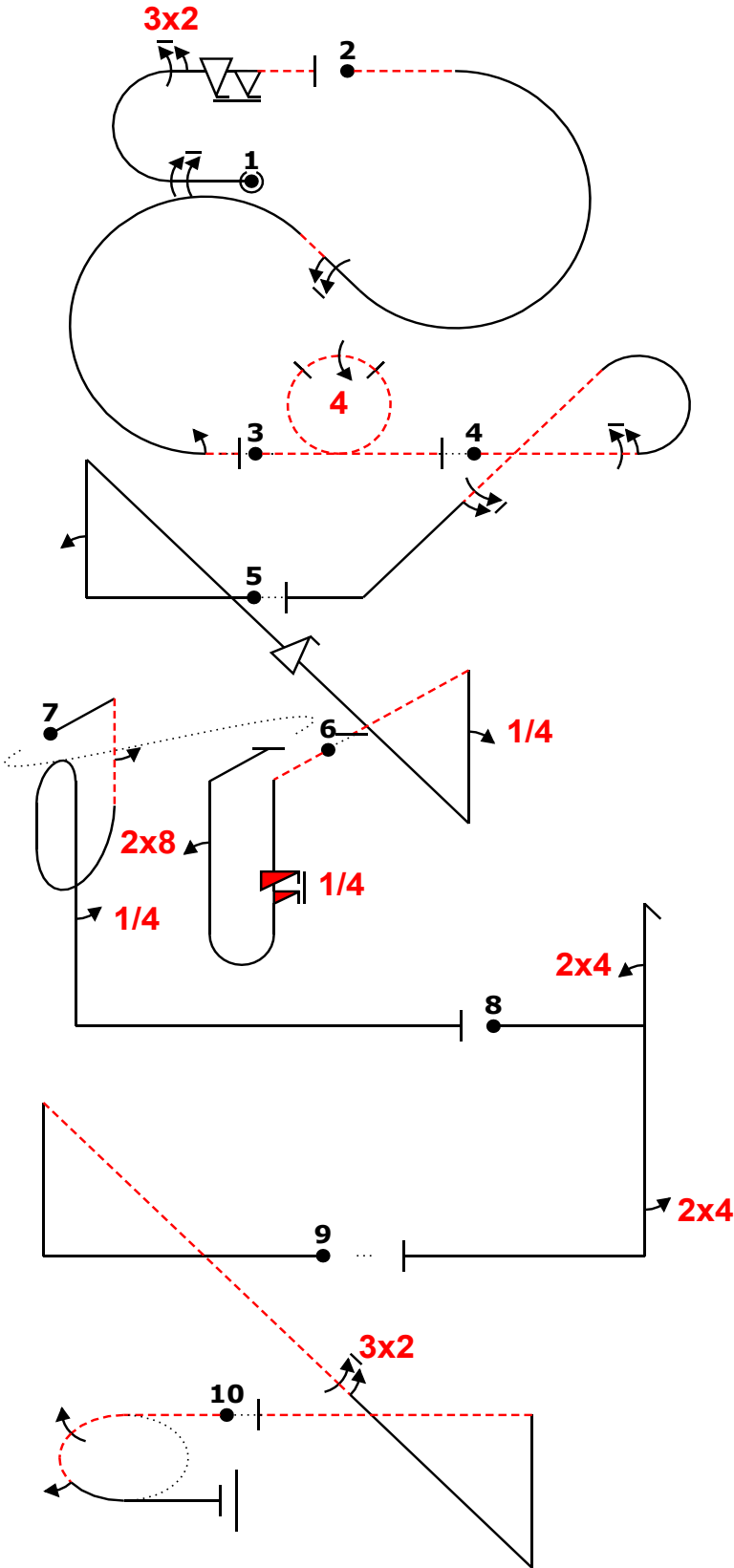

| Fig | Grade | Pos | Remarks |
|-----|-------|-----|---------|
| 1 | . | | |
| 2 | . | | |
| 3 | . | | |
| 4 | . | | |
| 5 | . | | |
| 6 | . | | |
| 7 | . | | |
| 8 | . | | |
| 9 | . | | |
| 10 | . | | |

| | | |
|-------------|----|---|
| Positioning | 30 | . |
|-------------|----|---|

| | | | |
|---------------|--|----------------|--|
| Too Low | | Trg Violation | |
| Too High | | Wing Rocks | |
| Interruptions | | Disqual Fig | |
| Insertions | | Other(note...) | |

ed "@A" -1% ,9m32,6f- 11% -.....iac(`6`)2-.....(-3,0) "@D" -2% -o44~ (-2,0) -2% -`6c...
 '6'~ (2,0) "@C" ++2`pn(...f...'),4~ (2,-1) "@E" ~5isib8 (-17,1) `2`ibb(...')...4.++++ ~+24
 h...'24'++++ (-1,0) ~++++(...32....)~ (2,0) "@B" -2jo15

| Fig 1 A | K | Fig 2 | K | Fig 3 D | K | Fig 4 | K | Fig 5 C | K | Fig 6 E | K | Fig 7 | K | Fig 8 | K | Fig 9 | K | Fig 10 B | K |
|---------|-----------|---------|-----------|---------|-----------|---------|-----------|----------|-----------|----------|-----------|---------|-----------|---------|-----------|----------|-----------|----------|-----------|
| 7.2.1.1 | 6 | 7.5.7.4 | 15 | 7.4.1.2 | 15 | 8.5.8.2 | 11 | 1.3.14.1 | 22 | 8.4.2.4 | 14 | 8.8.8.3 | 19 | 5.2.1.1 | 17 | 1.3.11.1 | 20 | 2.2.3.4 | 26 |
| 9.1.3.8 | 12 | 9.1.2.6 | 12 | 9.4.3.4 | 11 | 9.1.3.6 | 10 | 9.1.1.2 | 8 | 9.12.1.5 | 6 | 9.1.5.2 | 4 | 9.4.1.2 | 9 | 9.2.4.6 | 12 | | |
| 9.2.3.6 | 12 | 9.1.3.2 | 4 | | | 9.1.4.6 | 10 | 9.9.4.4 | 11 | 9.8.1.1 | 7 | 9.1.5.1 | 2 | 9.4.5.2 | 5 | | | | |
| 9.9.3.6 | 14 | | | | | 9.1.1.1 | 6 | | | | | | | | | | | | |
| | 44 | | 31 | | 26 | | 31 | | 47 | | 27 | | 25 | | 31 | | 32 | | 26 |

Pilot: Dan Stefanescu

A/C: EA330SC YR-EXC

Team: ROU

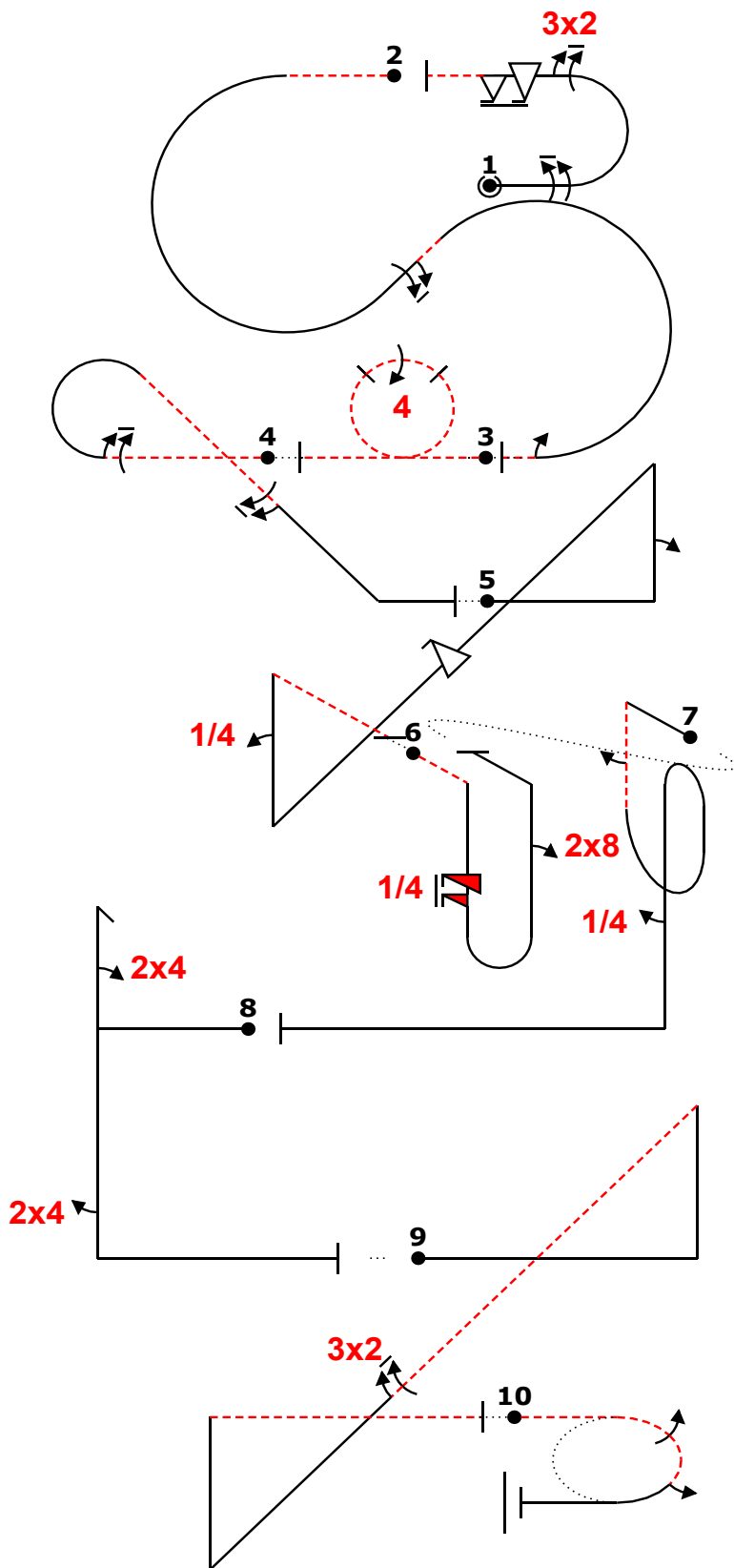
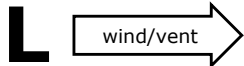

| Fig | Grade | Pos | Remarks |
|-----|-------|-----|---------|
| 1 | . | | |
| 2 | . | | |
| 3 | . | | |
| 4 | . | | |
| 5 | . | | |
| 6 | . | | |
| 7 | . | | |
| 8 | . | | |
| 9 | . | | |
| 10 | . | | |

Positioning

30

.

Too Low

Trg Violation

Too High

Wing Rocks

Interruptions

Disqual Fig

Insertions

Other(note...)

ed "@A" -1% ,9m32,6f- 11% -.....iac(`6`)2-.....(-3,0) "@D" -2% -o44~ (-2,0) -2% -`6c...
 '6'~ (2,0) "@C" ++2`pn(...'f...'),4~ (2,-1) "@E" ~5isib8 (-17,1) `2`ibb(...)...4.++++ ~+24
 h...'24'++++ (-1,0) +++++n(.....32.....)~ (2,0) "@B" -2jo15

| Fig 1 A | K | Fig 2 | K | Fig 3 D | K | Fig 4 | K | Fig 5 C | K | Fig 6 E | K | Fig 7 | K | Fig 8 | K | Fig 9 | K | Fig 10 B | K |
|---------|----|---------|----|---------|----|---------|----|----------|----|-----------|----|---------|----|---------|----|----------|----|----------|----|
| 7.2.1.1 | 6 | 7.5.7.4 | 15 | 7.4.1.2 | 15 | 8.5.8.2 | 11 | 1.3.14.1 | 22 | 8.4.2.4 | 14 | 8.8.8.3 | 19 | 5.2.1.1 | 17 | 1.3.11.1 | 20 | 2.2.3.4 | 26 |
| 9.1.3.8 | 12 | 9.1.2.6 | 12 | 9.4.3.4 | 11 | 9.1.3.6 | 10 | 9.1.1.2 | 8 | 9.1.2.1.5 | 6 | 9.1.5.2 | 4 | 9.4.1.2 | 9 | 9.2.4.6 | 12 | | |
| 9.2.3.6 | 12 | 9.1.3.2 | 4 | | | 9.1.4.6 | 10 | 9.9.4.4 | 11 | 9.8.1.1 | 7 | 9.1.5.1 | 2 | 9.4.5.2 | 5 | | | | |
| 9.9.3.6 | 14 | | | | | 9.1.1.1 | 6 | | | | | | | | | | | | |
| | 44 | | 31 | | 26 | | 31 | | 47 | | 27 | | 25 | | 31 | | 32 | | 26 |

wind/vent ← **R**

Figure K
320
Total K
350

Judges Name
Signature
Number

Flight #

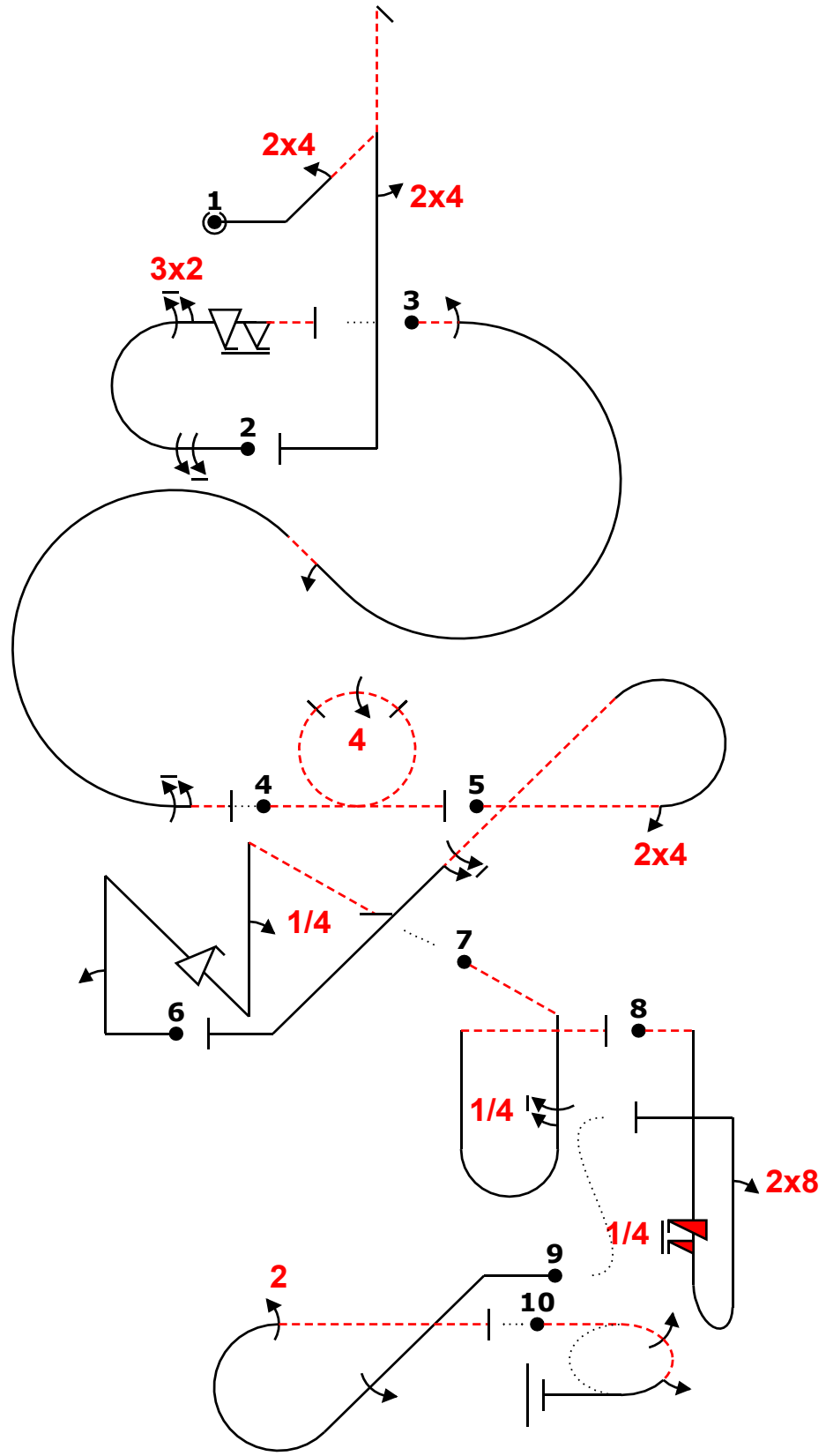

| Fig | Grade | Pos | Remarks |
|-----|-------|-----|---------|
| 1 | . | | |
| 2 | . | | |
| 3 | . | | |
| 4 | . | | |
| 5 | . | | |
| 6 | . | | |
| 7 | . | | |
| 8 | . | | |
| 9 | . | | |
| 10 | . | | |

Positioning
30

| | | | |
|---------------|--|----------------|--|
| Too Low | | Trg Violation | |
| Too High | | Wing Rocks | |
| Interruptions | | Disqual Fig | |
| Insertions | | Other(note...) | |

24dh24... 'low "@A" `9m32,6f-` (2,0) 15% -.....liac(.....)6..... (-2,0) -1% "@D" -o44- -`
`",24c... '6.. "@C" /2pn(f),4'---- (2,1) 5% -",5'ib'-----> "@E"5isib'..8 (-1,10) lirc22-` (-1,0) -2% "@
B" -2jo15

| Fig 1 | K | Fig 2 A | K | Fig 3 | K | Fig 4 D | K | Fig 5 | K | Fig 6 C | K | Fig 7 | K | Fig 8 E | K | Fig 9 | K | Fig 10 B | K |
|---------|-----------|---------|----|---------|----|---------|-----------|---------|-----------|----------|----|---------|-----------|----------|-----------|---------|-----------|----------|-----------|
| 5.3.2.1 | 24 | 7.2.1.1 | 6 | 7.5.7.4 | 15 | 7.4.1.2 | 15 | 8.5.8.2 | 11 | 1.3.14.1 | 22 | 8.4.1.4 | 13 | 8.4.2.4 | 14 | 8.5.1.3 | 10 | 2.2.3.4 | 26 |
| 9.4.2.2 | 7 | 9.1.3.8 | 12 | 9.1.3.4 | 8 | 9.4.3.4 | 11 | 9.4.3.2 | 5 | 9.1.1.2 | 8 | 9.1.5.5 | 9 | 9.12.1.5 | 6 | 9.1.4.4 | 8 | | |
| 9.4.5.2 | 5 | 9.2.3.6 | 12 | 9.1.2.2 | 6 | | | 9.1.4.6 | 10 | 9.9.4.4 | 11 | | | 9.8.1.1 | 7 | 9.2.3.4 | 9 | | |
| | 36 | 9.9.3.6 | 14 | 9.1.3.6 | 10 | | 26 | | 26 | 9.1.1.1 | 6 | | 22 | | 27 | | 27 | | 26 |

Pilot: Ioan Ursu

A/C: Extra 330SC YR-EXB Team: ROU

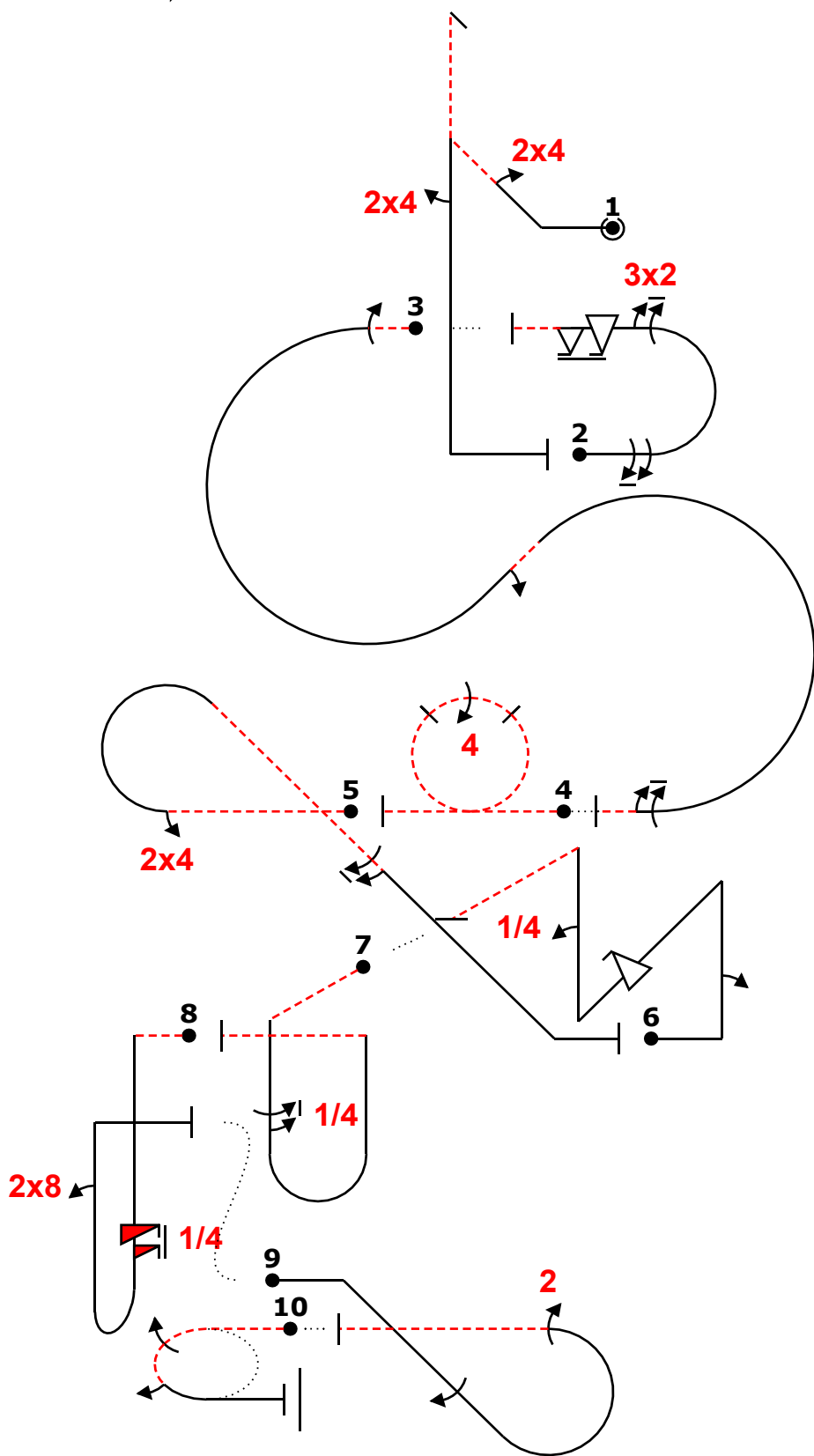
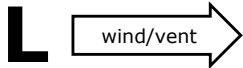

| Fig | Grade | Pos | Remarks |
|-----|-------|-----|---------|
| 1 | . | | |
| 2 | . | | |
| 3 | . | | |
| 4 | . | | |
| 5 | . | | |
| 6 | . | | |
| 7 | . | | |
| 8 | . | | |
| 9 | . | | |
| 10 | . | | |

Positioning
30

| | | | |
|---------------|--|----------------|--|
| Too Low | | Trg Violation | |
| Too High | | Wing Rocks | |
| Interruptions | | Disqual Fig | |
| Insertions | | Other(note...) | |

24dh24... 'low "@A" `9m32,6f-` (2,0) 15%liac("2")6-..... (-2,0) -1% "@D" -o44- -`
 `",24c... '6.. "@C" /2pn(f),4'---- (2,1) 5% -",5'ib'-----> "@E"5isib' ,8 (-1,10) lirc22-` (-1,0) -2% "@
 B" -2jo15

| Fig 1 | K | Fig 2 A | K | Fig 3 | K | Fig 4 D | K | Fig 5 | K | Fig 6 C | K | Fig 7 | K | Fig 8 E | K | Fig 9 | K | Fig 10 B | K |
|---------|----|---------|----|---------|----|---------|----|---------|----|----------|----|---------|----|----------|----|---------|----|----------|----|
| 5.3.2.1 | 24 | 7.2.1.1 | 6 | 7.5.7.4 | 15 | 7.4.1.2 | 15 | 8.5.8.2 | 11 | 1.3.14.1 | 22 | 8.4.1.4 | 13 | 8.4.2.4 | 14 | 8.5.1.3 | 10 | 2.2.3.4 | 26 |
| 9.4.2.2 | 7 | 9.1.3.8 | 12 | 9.1.3.4 | 8 | 9.4.3.4 | 11 | 9.4.3.2 | 5 | 9.1.1.2 | 8 | 9.1.5.5 | 9 | 9.12.1.5 | 6 | 9.1.4.4 | 8 | | |
| 9.4.5.2 | 5 | 9.2.3.6 | 12 | 9.1.2.2 | 6 | | | 9.1.4.6 | 10 | 9.9.4.4 | 11 | | | 9.8.1.1 | 7 | 9.2.3.4 | 9 | | |
| | 36 | 9.9.3.6 | 14 | 9.1.3.6 | 10 | | 26 | | 26 | 9.1.1.1 | 6 | | 22 | | 27 | | 27 | | 26 |

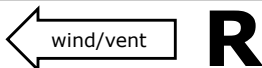
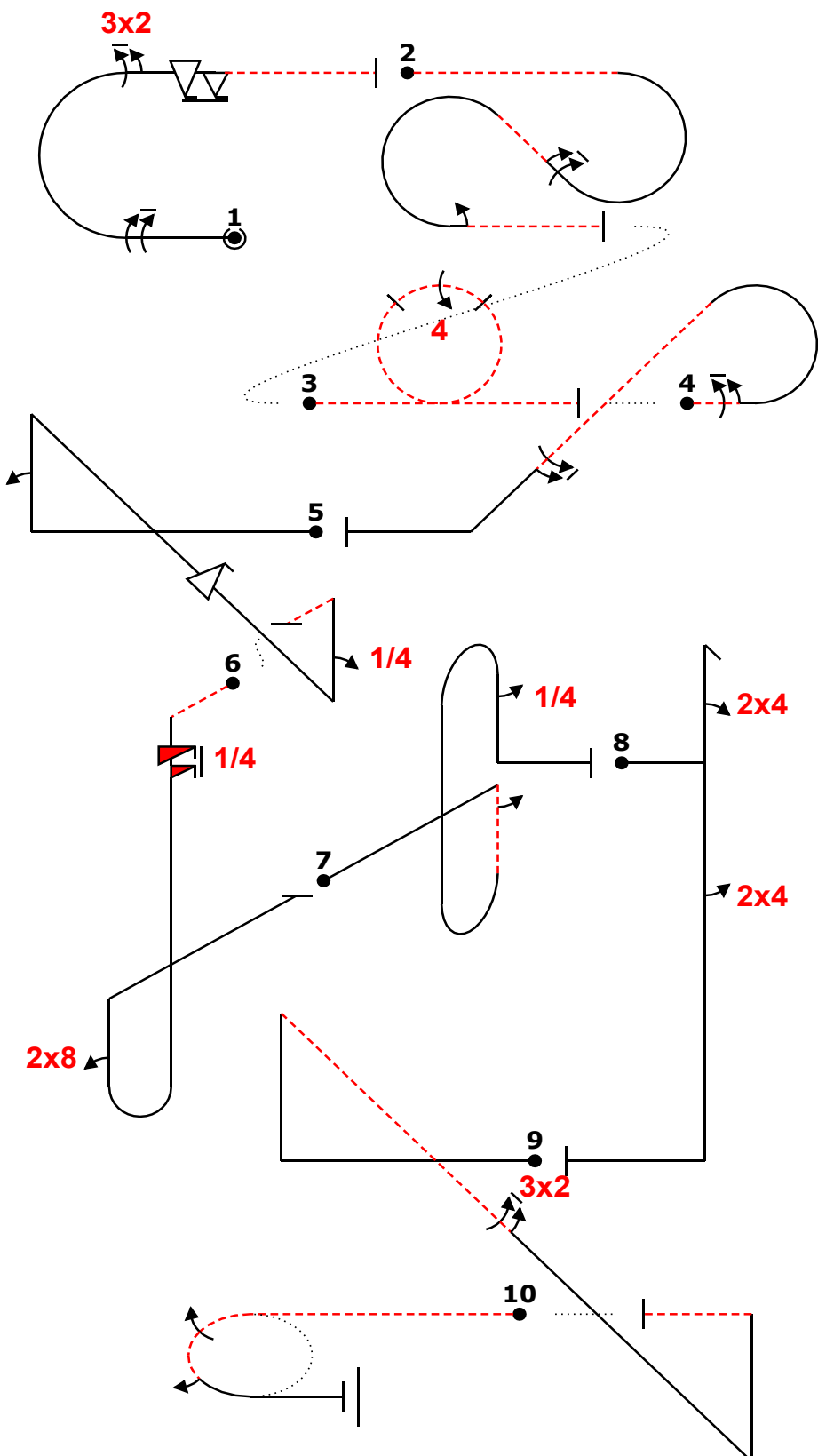

Figure K
320
Total K
350

| | |
|-------------|--------|
| Judges Name | |
| Signature | Number |

Flight #



| Fig | Grade | Pos | Remarks |
|-----|-------|-----|---------|
| 1 | . | | |
| 2 | . | | |
| 3 | . | | |
| 4 | . | | |
| 5 | . | | |
| 6 | . | | |
| 7 | . | | |
| 8 | . | | |
| 9 | . | | |
| 10 | . | | |

Positioning
30

| | | | |
|---------------|--|----------------|--|
| Too Low | | Trg Violation | |
| Too High | | Wing Rocks | |
| Interruptions | | Disqual Fig | |
| Insertions | | Other(note...) | |

ed "@A" 4% ,9m32,6f-- 1% ~~~~~ iac(' ,6')'2- ~~~~~ (-23,12) "@0" ~-o44-- (3,0) ~~~~~ 6'c....6' ~~~~ "@C"
 ~~~~~+2' ~~~~pn(...'f..') ~~~~~,4~ (0,2) "@E" ~~~~~5is.....'ib' ~~~~8++++~ 5% + ~~~~~2' ~~~~ibb(' ~~~~~)'4+' ~~~~,24h.' ~~~~24  
 .....'+~ ~~~~~+~n(.....32.....)-- (-4,0) "@B" ~~~~~-2jo15

| Fig 1 A | K  | Fig 2   | K  | Fig 3 D | K  | Fig 4   | K  | Fig 5 C  | K  | Fig 6 E  | K  | Fig 7   | K  | Fig 8   | K  | Fig 9    | K  | Fig 10 B | K  |
|---------|----|---------|----|---------|----|---------|----|----------|----|----------|----|---------|----|---------|----|----------|----|----------|----|
| 7.2.1.1 | 6  | 7.5.7.4 | 15 | 7.4.1.2 | 15 | 8.5.8.2 | 11 | 1.3.14.1 | 22 | 8.4.2.4  | 14 | 8.8.8.3 | 19 | 5.2.1.1 | 17 | 1.3.11.1 | 20 | 2.2.3.4  | 26 |
| 9.1.3.8 | 12 | 9.1.2.6 | 12 | 9.4.3.4 | 11 | 9.1.3.6 | 10 | 9.1.1.2  | 8  | 9.12.1.5 | 6  | 9.1.5.2 | 4  | 9.4.1.2 | 9  | 9.2.4.6  | 12 |          |    |
| 9.2.3.6 | 12 | 9.1.3.2 | 4  |         |    | 9.1.4.6 | 10 | 9.9.4.4  | 11 | 9.8.1.1  | 7  | 9.1.5.1 | 2  | 9.4.5.2 | 5  |          |    |          |    |
| 9.9.3.6 | 14 |         |    |         |    |         |    | 9.1.1.1  | 6  |          |    |         |    |         |    |          |    |          |    |
|         | 44 |         | 31 |         | 26 |         | 31 |          | 47 |          | 27 |         | 25 |         | 31 |          | 32 |          | 26 |



Figure K  
320  
Total K  
350

|             |        |
|-------------|--------|
| Judges Name |        |
| Signature   | Number |

Flight #

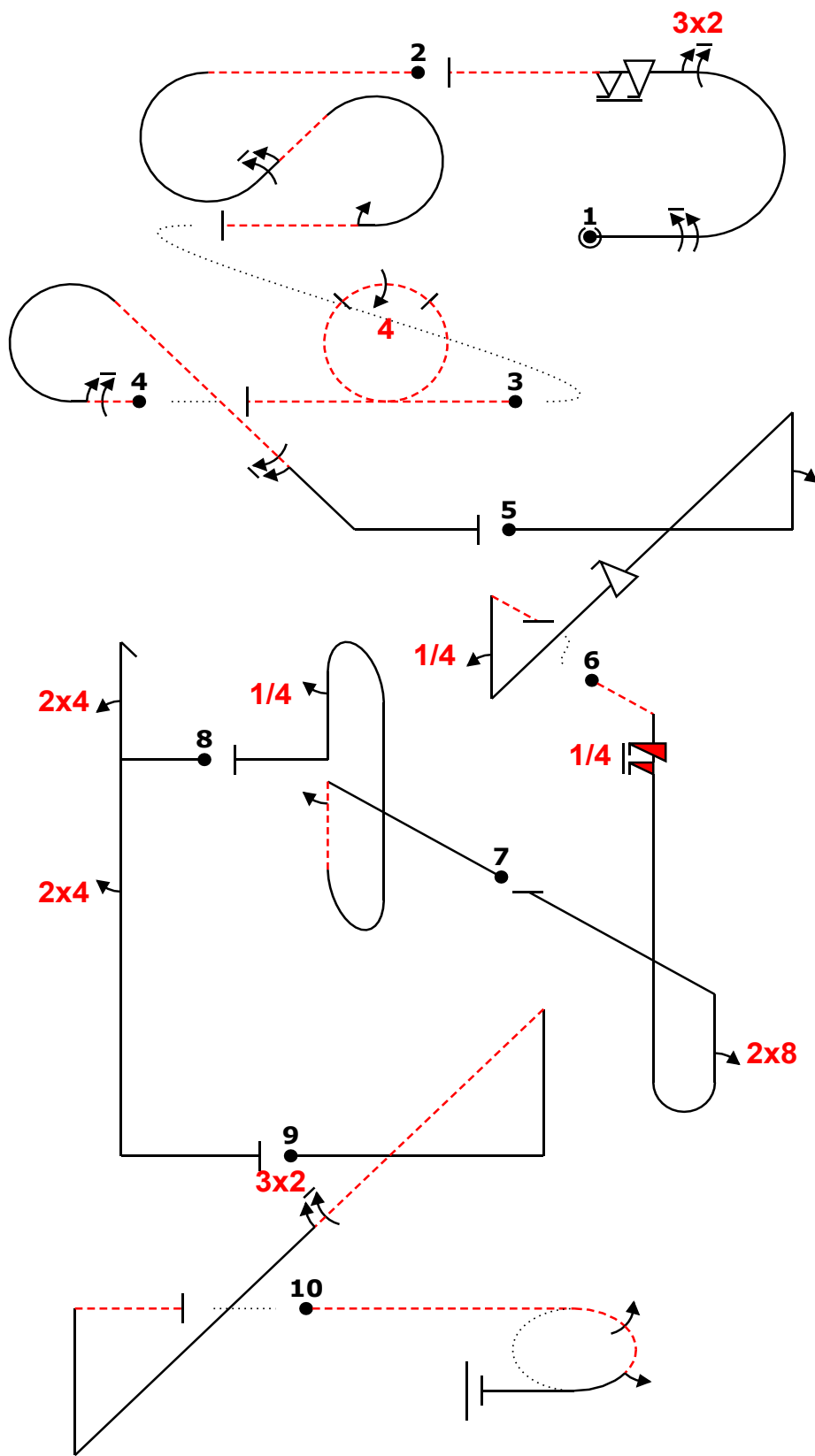
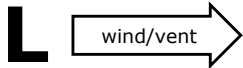

| Fig | Grade | Pos | Remarks |
|-----|-------|-----|---------|
| 1   | .     |     |         |
| 2   | .     |     |         |
| 3   | .     |     |         |
| 4   | .     |     |         |
| 5   | .     |     |         |
| 6   | .     |     |         |
| 7   | .     |     |         |
| 8   | .     |     |         |
| 9   | .     |     |         |
| 10  | .     |     |         |

Positioning  
30

|               |  |                |  |
|---------------|--|----------------|--|
| Too Low       |  | Trg Violation  |  |
| Too High      |  | Wing Rocks     |  |
| Interruptions |  | Disqual Fig    |  |
| Insertions    |  | Other(note...) |  |

ed "@A" 4% ,9m32,6f-- 1% ~~~~~iac('',6')\*2-~~~~~ (-23,12) "@0" ~~~o44-- (3,0) ~~~~~6'c....6''~ ~"@C"  
 ~~~~~+2''pn(...'f..')''''4~ (0,2) "@E" ~~~~~5is.....'ib''''8++++~ 5% ++''''2''ibb('''''')'4+' ~,24h.'24  
'+~ +++n(....32.....)-- (-4,0) "@B" ~~~~~2jo15

| Fig 1 A | K | Fig 2 | K | Fig 3 D | K | Fig 4 | K | Fig 5 C | K | Fig 6 E | K | Fig 7 | K | Fig 8 | K | Fig 9 | K | Fig 10 B | K |
|---------|----|---------|----|---------|----|---------|----|----------|----|----------|----|---------|----|---------|----|----------|----|----------|----|
| 7.2.1.1 | 6 | 7.5.7.4 | 15 | 7.4.1.2 | 15 | 8.5.8.2 | 11 | 1.3.14.1 | 22 | 8.4.2.4 | 14 | 8.8.8.3 | 19 | 5.2.1.1 | 17 | 1.3.11.1 | 20 | 2.2.3.4 | 26 |
| 9.1.3.8 | 12 | 9.1.2.6 | 12 | 9.4.3.4 | 11 | 9.1.3.6 | 10 | 9.1.1.2 | 8 | 9.12.1.5 | 6 | 9.1.5.2 | 4 | 9.4.1.2 | 9 | 9.2.4.6 | 12 | | |
| 9.2.3.6 | 12 | 9.1.3.2 | 4 | | | 9.1.4.6 | 10 | 9.9.4.4 | 11 | 9.8.1.1 | 7 | 9.1.5.1 | 2 | 9.4.5.2 | 5 | | | | |
| 9.9.3.6 | 14 | | | | | | | 9.1.1.1 | 6 | | | | | | | | | | |
| | 44 | | 31 | | 26 | | 31 | | 47 | | 27 | | 25 | | 31 | | 32 | | 26 |



Figure K
320
Total K
350

| | |
|-------------|--------|
| Judges Name | |
| Signature | Number |

Flight #

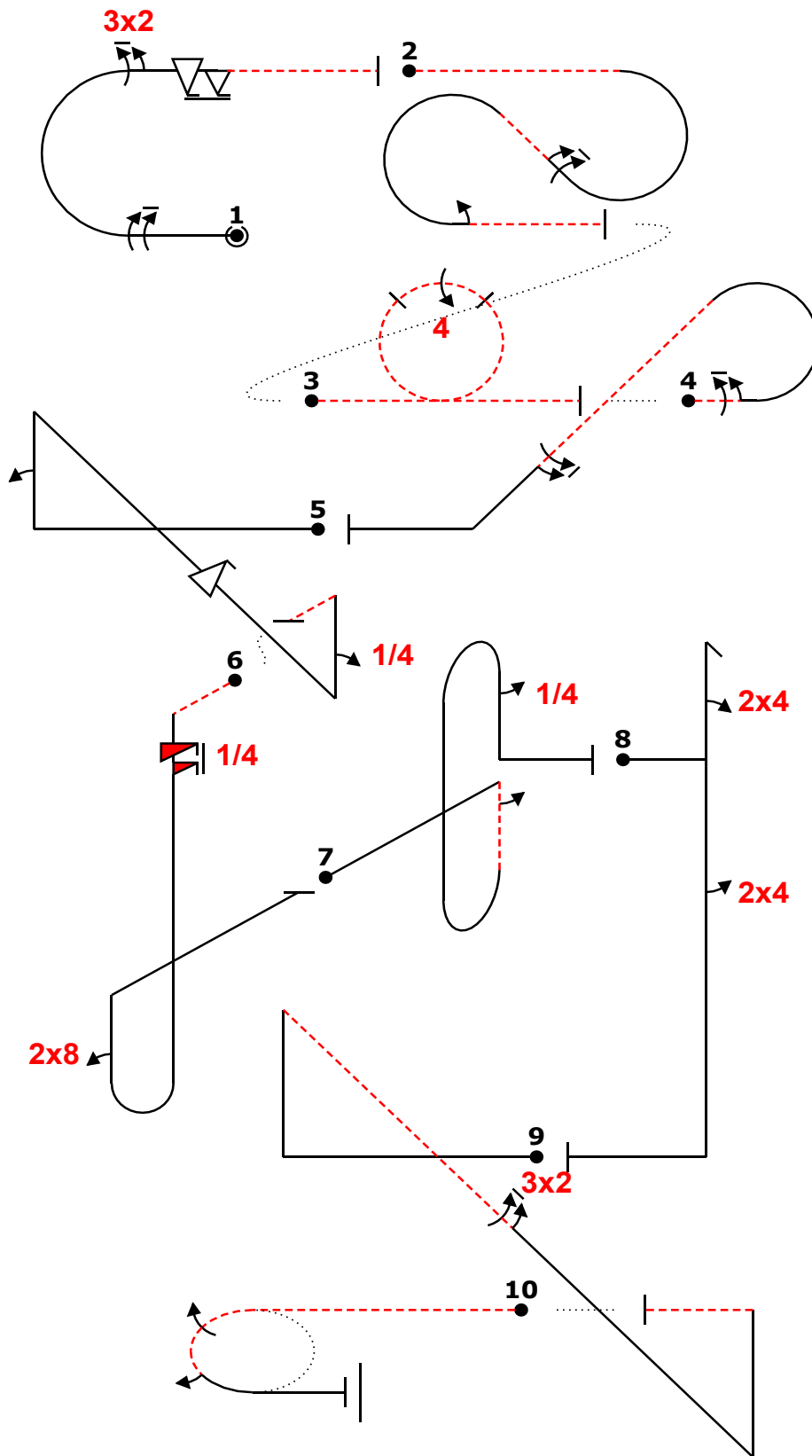
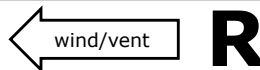

| Fig | Grade | Pos | Remarks |
|-----|-------|-----|---------|
| 1 | . | | |
| 2 | . | | |
| 3 | . | | |
| 4 | . | | |
| 5 | . | | |
| 6 | . | | |
| 7 | . | | |
| 8 | . | | |
| 9 | . | | |
| 10 | . | | |

Positioning
30

| | | | |
|---------------|--|----------------|--|
| Too Low | | Trg Violation | |
| Too High | | Wing Rocks | |
| Interruptions | | Disqual Fig | |
| Insertions | | Other(note...) | |

ed "@A" 4% ,9m32,6f-- 1% ~~~~~ iac(' ,6')*2- ~~~~~ (-23,12) "@D" ~~~o44-- (3,0) ~~~~~ 6'c....6' ~~~+~ "@C"
 ~~~~~+2' ~~~pn(...'f..') ~~~~~ ,4~ (0,2) "@E" ~~~~~ 5is..... 'ib' ~~~ 8++++~ 5% +~ ~~~ 2' ~~~ibb(~~~~~)'4'+ ~~~ ,24h..''24  
 .....'+~ ~~~+~n(.....32.....)-- (-4,0) "@B" ~~~~~2jo15

| Fig 1 A | K  | Fig 2   | K  | Fig 3 D | K  | Fig 4   | K  | Fig 5 C  | K  | Fig 6 E   | K  | Fig 7   | K  | Fig 8   | K  | Fig 9    | K  | Fig 10 B | K  |
|---------|----|---------|----|---------|----|---------|----|----------|----|-----------|----|---------|----|---------|----|----------|----|----------|----|
| 7.2.1.1 | 6  | 7.5.7.4 | 15 | 7.4.1.2 | 15 | 8.5.8.2 | 11 | 1.3.14.1 | 22 | 8.4.2.4   | 14 | 8.8.8.3 | 19 | 5.2.1.1 | 17 | 1.3.11.1 | 20 | 2.2.3.4  | 26 |
| 9.1.3.8 | 12 | 9.1.2.6 | 12 | 9.4.3.4 | 11 | 9.1.3.6 | 10 | 9.1.1.2  | 8  | 9.1.2.1.5 | 6  | 9.1.5.2 | 4  | 9.4.1.2 | 9  | 9.2.4.6  | 12 |          |    |
| 9.2.3.6 | 12 | 9.1.3.2 | 4  |         |    | 9.1.4.6 | 10 | 9.9.4.4  | 11 | 9.8.1.1   | 7  | 9.1.5.1 | 2  | 9.4.5.2 | 5  |          |    |          |    |
| 9.9.3.6 | 14 |         |    |         |    |         |    | 9.1.1.1  | 6  |           |    |         |    |         |    |          |    |          |    |
|         | 44 |         | 31 |         | 26 |         | 31 |          | 47 |           | 27 |         | 25 |         | 31 |          | 32 |          | 26 |

Pilot: Markus Ruesch

A/C: Extra 300LC SP-DMK Team: SUI



Figure K  
320  
Total K  
350

|             |        |          |
|-------------|--------|----------|
| Judges Name |        | Flight # |
| Signature   | Number |          |

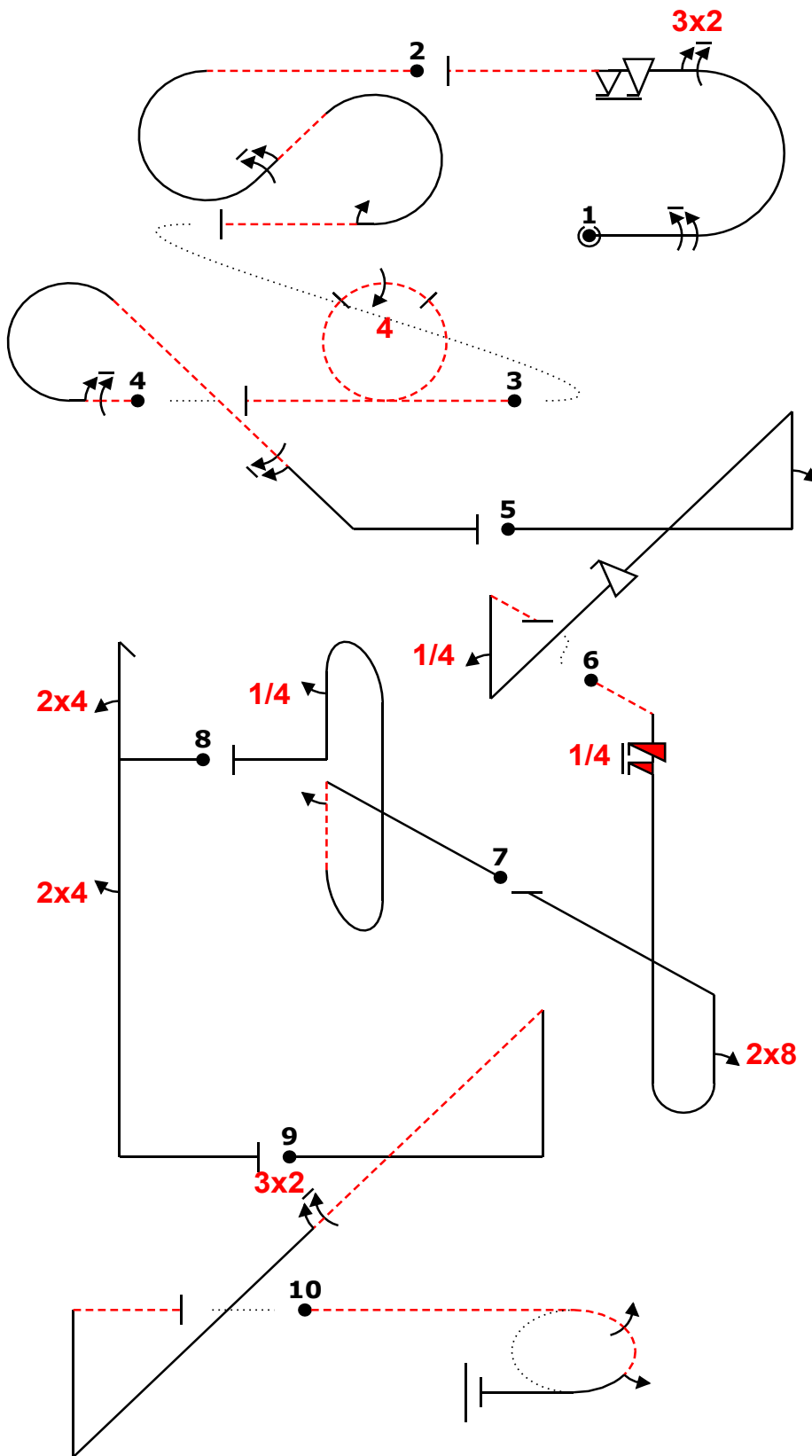
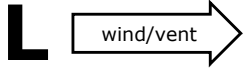

| Fig | Grade | Pos | Remarks |
|-----|-------|-----|---------|
| 1   | .     |     |         |
| 2   | .     |     |         |
| 3   | .     |     |         |
| 4   | .     |     |         |
| 5   | .     |     |         |
| 6   | .     |     |         |
| 7   | .     |     |         |
| 8   | .     |     |         |
| 9   | .     |     |         |
| 10  | .     |     |         |

Positioning  
30

|               |  |                |  |
|---------------|--|----------------|--|
| Too Low       |  | Trg Violation  |  |
| Too High      |  | Wing Rocks     |  |
| Interruptions |  | Disqual Fig    |  |
| Insertions    |  | Other(note...) |  |

ed "@A" 4% ,9m32,6f-- 1% ~~~~~iac(`,6')\*2-~~~~~ (-23,12) "@0" ~~~o44-- (3,0) ~~~~~6'c....6'~~~ "@C"  
 ~~~~~+2"pn(...'f..')~~~~~ (0,2) "@E" ~~~~~5is.....'ib~~~~~8++++~ 5% ++~~~~~2'ibb(~~~~~)'4+' ~~,24h.'24  
'+~ +++n(.....32.....)-- (-4,0) "@B" ~~~~~2jo15

| Fig 1 A | K | Fig 2 | K | Fig 3 D | K | Fig 4 | K | Fig 5 C | K | Fig 6 E | K | Fig 7 | K | Fig 8 | K | Fig 9 | K | Fig 10 B | K |
|---------|----|---------|----|---------|----|---------|----|----------|----|----------|----|---------|----|---------|----|----------|----|----------|----|
| 7.2.1.1 | 6 | 7.5.7.4 | 15 | 7.4.1.2 | 15 | 8.5.8.2 | 11 | 1.3.14.1 | 22 | 8.4.2.4 | 14 | 8.8.8.3 | 19 | 5.2.1.1 | 17 | 1.3.11.1 | 20 | 2.2.3.4 | 26 |
| 9.1.3.8 | 12 | 9.1.2.6 | 12 | 9.4.3.4 | 11 | 9.1.3.6 | 10 | 9.1.1.2 | 8 | 9.12.1.5 | 6 | 9.1.5.2 | 4 | 9.4.1.2 | 9 | 9.2.4.6 | 12 | | |
| 9.2.3.6 | 12 | 9.1.3.2 | 4 | | | 9.1.4.6 | 10 | 9.9.4.4 | 11 | 9.8.1.1 | 7 | 9.1.5.1 | 2 | 9.4.5.2 | 5 | | | | |
| 9.9.3.6 | 14 | | | | | | | 9.1.1.1 | 6 | | | | | | | | | | |
| | 44 | | 31 | | 26 | | 31 | | 47 | | 27 | | 25 | | 31 | | 32 | | 26 |